

Operating Manual

+ Initial start up Pellet heating system with auger delivery system or vacuum suction system for professionals

**PELLEMATIC®
PE(S)(K)(B) 10 – 56**

FA_V2.03

Pelletronic TOUCH

ENGLISH





Title: Operating Manual PELLEMATIC® PE(S)(K)(B) 10 – 56

Article number: PE 567 EN 1.1

Version valid
from: 06/2015

Approved: Wohlinger Christian

Author

ÖkoFEN Forschungs- &
EntwicklungsgesmbH
A-4133 Niederkappel, Gewerbepark 1
Tel.: +43 (0) 72 86 / 74 50
Fax.: +43 (0) 72 86 / 74 50 - 10
E-Mail: oekofen@pelletsheizung.at
www.oekofen.com

© by ÖkoFEN Forschungs- und EntwicklungsgesmbH
Subject to modifications

1	Dear Customer	5
2	Use only for the purpose intended	6
3	Types of safety warning sign.....	7
4	System overview	8
5	Control system	10
6	Parameter Adjustments.....	11
7	The boiler controller	12
7.1	Plugs on the boiler control unit	13
7.2	Wiring diagrams	15
7.3	LED status boiler controller.....	19
7.4	Cable Routing.....	19
8	The heating controller.....	20
8.1	LED status heating controller	21
8.2	Connection plan	22
	8.2.1 Jumper X34 for analog voltage outputs X11 (OUT1) and X21 (OUT2)	25
8.3	Rules of wiring for micronetwork with 1,2 or more heating controllers.....	25
8.4	Wiring diagrams.....	26
8.5	Assembly and disassembly of the heating controller circuit board	28
8.6	Cable specification Pelletronic Touch.....	30
8.7	Sensor values.....	31
8.8	Hydraulic connecting diagrams.....	32
	8.8.1 Hydraulic connecting diagrams Pelletronic Touch	32
9	The Touch operating device.....	41
9.1	User controls and their function	43
9.2	Main Menu	45
9.3	Replacing a Touch operating device	46
9.4	Backside of the Touch operating device	47
9.5	Calibration	48
10	Default values and settings.....	49
11	Default values and settings	53
12	Online Touch	57
12.1	Product Description.....	57
	12.1.1 Installation Requirements	57
	12.1.2 System Description.....	58
12.2	Settings on the Touch Operating Device.....	59
12.3	Opening the Password-Protected Remote Maintenance Website	61
12.4	Description of the Pelletronic Online Website.....	62
	12.4.1 Making Settings	63
	12.4.2 Adjustment of the power rating	64
	12.4.3 Error Messages by E-mail	65
	12.4.4 Quit malfunction.....	67
	12.4.5 Code input.....	68
13	Starting up for the first time.....	69
13.1	Performance adjustment	70
13.2	Setting the addresses of the Bus-participants.....	70
	13.2.1 Setting the address at the burner controller	70
	13.2.2 Setting the address at the heating controller	71
	13.2.3 Setting the adress for the remote control	72
	13.2.4 Settings before starting up.....	72
	13.2.5 Setting the adress for remote control Touch	73
	13.2.6 Setting the adress for remote control	74
	13.2.7 Code Input.....	75
	13.2.8 Periphery Learning.....	77
	13.2.9 Flowtronic.....	84
13.3	Mode.....	84
	13.3.1 Operation mode.....	85
	13.3.2 Operation mode HC 1.....	85

13.3.3	Operation mode HC 2-6	85
13.3.4	Operation Mode DHW	86
13.3.5	Operation mode solar	86
13.3.6	Operation mode Pellematic	87
13.4	Measuring values.....	87
13.5	Weather.....	88
13.6	Eco Mode	89
13.7	Heating Circuit.....	91
13.7.1	Screed programme.....	94
13.8	Solar Heating.....	94
13.8.1	Menu Solar Heating.....	95
13.9	DHW settings.....	96
13.10	DHW Return Pump settings	97
13.11	Solar settings	98
13.12	Accumulator settings.....	104
13.13	System Regulation.....	106
13.13.1	Cascade settings.....	107
13.13.2	Existing Boiler	111
13.14	Pellematic settings.....	113
13.14.1	Outertemperature control.....	114
13.14.2	External Power Ventilator.....	115
13.14.3	Permanent operation.....	115
13.14.4	Ignition settings	116
13.14.5	Full power settings	117
13.14.6	Run Down Time settings.....	118
13.14.7	De-ashing system settings	119
13.14.8	Boiler cleaning	121
13.14.9	Negative Draft	122
13.14.10	FRT Controller	123
13.14.11	Level detection system	125
13.14.12	Boiler Controlled Pump	126
13.14.13	Suction turbine	128
13.14.14	Output Settings.....	129
13.14.15	Output Test.....	130
13.14.16	Maintenance	132
13.14.17	Calibrate.....	133
13.14.18	Magnet Valve.....	134
13.14.19	Settings.....	135
13.15	Heating Main Pump.....	137
13.16	General settings	138
13.16.1	Chimney.....	141
13.16.2	Datalog.....	142
13.16.3	Delete Log.....	143
13.16.4	ModBUS.....	144
13.16.5	E-Mail	146
13.16.6	IP Config	147
13.16.7	USB	150
13.17	Software settings	151
13.17.1	Configuration.....	151
13.17.2	Function room sensor.....	152
13.17.3	Update Heating Controller, Touch Operating device and Remote Control.....	152
13.17.4	Software Update.....	153
14	Appendix.....	154
14.1	Malfunctions.....	154
14.1.1	Malfunctions - what to do.....	154
14.1.2	Fault texts	154
14.1.3	Malfunction report	155

1 Dear Customer

ÖkoFEN is Europe's leading specialist in pellet heating.

Proficiency, innovation and quality combined. This is the tradition on which ÖkoFEN shapes the future. We are very pleased that you too have decided to purchase a product from ÖkoFEN.

- This manual is intended to help you operate the product safely, properly and economically.
- Please read this manual right through and take note of the safety warnings.
- Keep all documentation supplied with this unit in a safe place for future reference.
Please pass on the documentation to the new user if you decide to part with the unit at a later date.
- Please contact your authorised dealer if you have any questions.



ÖkoFEN attaches great importance to the development of new products. Our R&D Department repeatedly challenges the effectiveness of tried-and-tested systems and works continuously on improvements. In this way, we secure our technological advantage. We have already received many national and international awards for our products.

All our products comply with European standards in respect of quality, efficiency and emissions.

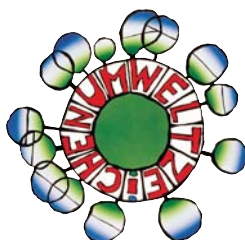

2 Use only for the purpose intended

The pellet heating system is designed to heat water for central or other indirect heating systems and hot water supply for buildings. It is not permissible to use the pellet heating system for any other purpose. Reasonable foreseeable inadvertent uses for the heating system are not known.

EG – KONFORMITÄTSERKLÄRUNG

Im Sinne der EG-Maschinenrichtlinie 2006/42/EG, Anhang II A

Der Hersteller erklärt, dass die/der in dieser Dokumentation beschriebene neu Maschinenteil/ Maschinenkomponente aufgrund ihrer Konzipierung und Bauart, sowie in der von uns in Verkehr gebrachten Ausführung mit den Bestimmungen der Maschinen - Sicherheitsverordnung – MSV2010, BGBl. Nr.282/2008 und damit der durch sie umgesetzten EG-Maschinenrichtlinie 89/392/EWG, zuletzt geändert durch 2006/42/EG in der geltenden Fassung übereinstimmt.

Hersteller / Firma

Ökofen Forschungs- und Entwicklungsgesellschaft. m.b.H.
Gewerbepark 1
A-4133 Niederkappel

Bezeichnung:

PELLEMATIC PE(S) 08, 10, 12, 15, 20, 25, 32, 36, 48 und 56 kW

PELLEMATIC PE(S)K 10, 12, 15, 20, 25 und 32 kW

Bei der Auslegung und dem Bau der Maschine wurden folgende Bestimmungen, Normen und Richtlinien berücksichtigt:

Einschlägige Bestimmungen:

2006/42EG	Maschinenrichtlinie in der geltenden Fassung
2006/95EG	Niederspannungsrichtlinie
2004/108/EG	EMV- Richtlinie elektromagnetische Verträglichkeit

Angewandte europäische/ nationale Normen und Richtlinien:

EN 292-1 und EN292-2	Sicherheit von Maschinen
EN 303-5	Heizkessel für feste Brennstoffe
EN 50081-1 und EN 50082-1	elektromagnetische Verträglichkeit
ISO 9001,	
ÖNORM M7550, B8130 und B8131	
sowie die technischen Richtlinien TRVB H 118 vorbeugender Brandschutz	

Niederkappel, am 12.09.2013



Ing. Herbert Ortner
Geschäftsführer

3 Types of safety warning sign

The warning signs use the following symbols and texts.

Types of safety warning sign

1. Risk of injury
2. Consequences of risk
3. Avoiding risk



1. Risk of injury:

Danger - indicates a situation that could lead to death or life-threatening injury.



Warning - indicates a situation that could lead life-threatening or serious injury.



Caution - indicates a situation that could lead to injury.



Note - indicates a situation that could lead to property damage.



2. Consequences of risk

Effects and consequences resulting from incorrect operation.

3. Avoiding risk

Observing safety instructions ensures that the heating system is operated safely

4 System overview

The whole system consists of following components:

- **Pellematic boiler:**
 - PE - Boiler with pellets transport auger as delivery system
 - PES - Boiler with vacuum suction system as delivery system
 - PEB - Boiler with hopper for hand filling
 - PESKA - cascade with up to 4 possible boilers
- **Pellet storage room** with pellet-delivery system:
 - Storage room
 - Textile tank
- **Possible additional components:**
 - Domestic hot water
 - Accumulator
 - Solar thermal panel
 - Existing external boiler

Pellematic with storage room and auger delivery



Pellematic with textile tank and auger delivery



Pellematic with storage room and vacuum suction



Pellematic with textile tank and vacuum suction



Pellematic cascade with textile tank and auger delivery system**Pellematic with hopper for hand filling**

NOTICE

There are separate manuals for all components, which describe functions and installation in detail.

5 Control system

Basically the Controlsystem consists of following components:

- **Pellematic boiler controller:**

The boiler controller controls all boiler functions (pellet feed system, combustion, deashing, etc.)

- **Pelletronic heating controller** (max. 3 wall boxes = 6 zones, 3 domestic hot water, 3 accumulators)

The heating controller regulates the whole heat distribution system. (Room temperature, domestic hot water, time programmes, solar, accumulator management, etc.)

Additionally **remote controls** can be installed in the system. These can be connected to the heat controller by a bus-connection.

- **Touch Operating Device**

The Touch Operating Device is in the boiler. It is connected by a bus-connection with both, heating- and boiler controller. It serves for:

- visualizing the measuring values
- adjusting the desired values and the time programme on the heating controller.
- adjusting the parameters of the boiler controller

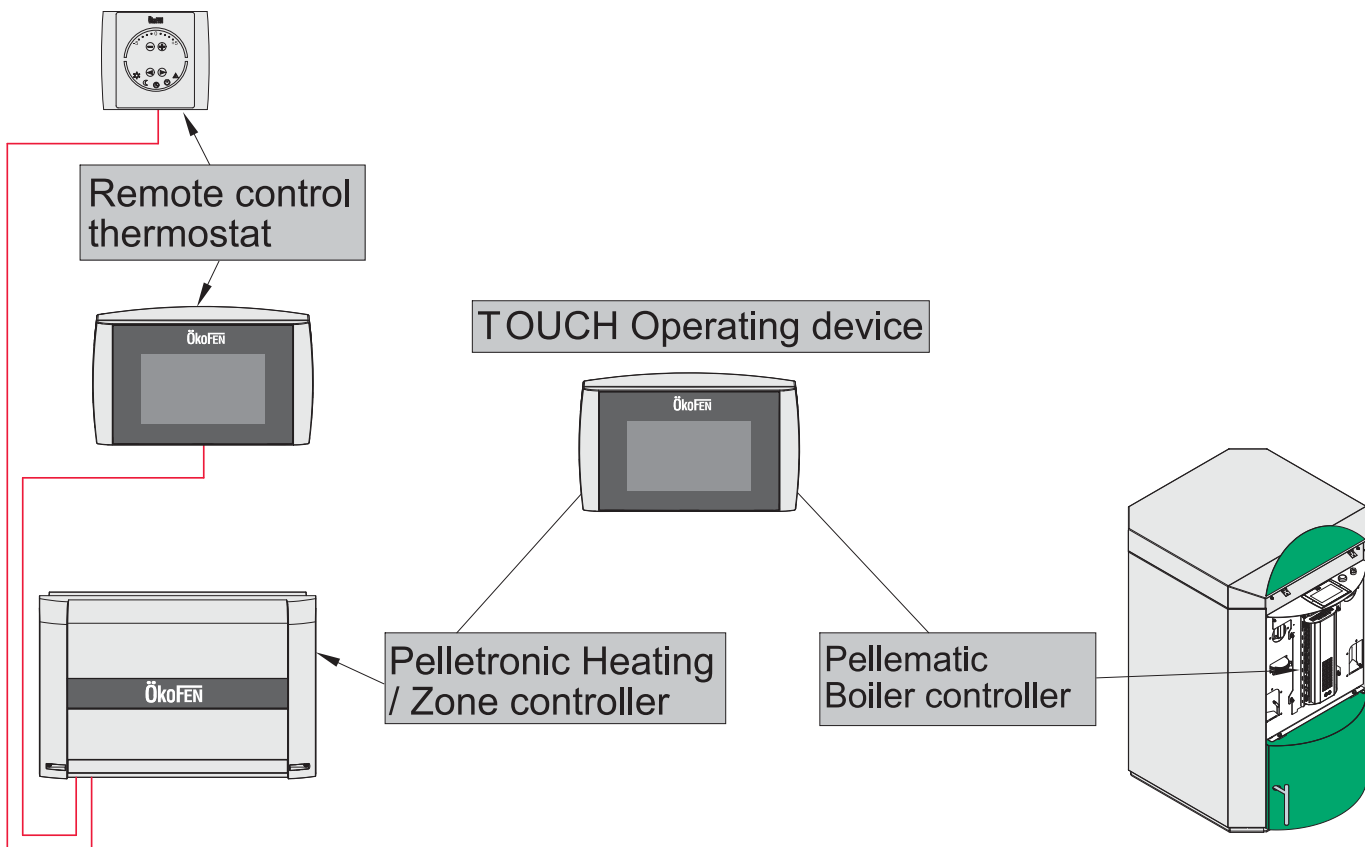

6 Parameter Adjustments

There are two areas in which adjustments can be set:

- **User-specific adjustments:** e.g. Room temperature, Time program, Domestic hot water temperature, Domestic hot water time program, Party-function etc.
- **System-specific adjustments:** e.g. combustion temperature regulation, deashing, ignition parameters, suction interval, etc.

Ex works, adjustments are basically set, so no further adaption is necessary.

A detailed description of all important setting options for the end user is to be found in the operating manual of the End User.

7 The boiler controller

The boiler controller is directly on the Pellematic boiler behind the half-round front cover of the boiler. It is used to control the combustion process and the fuel-feeding system.

The boiler controller is connected to the touch operating device by a bus-connection.

The Touch allows the owner / operator to see important measured values and Change to "Provides for adjustment of desired values and parameters of boiler operation. Only authorized installers should adjust boiler operating parameters."

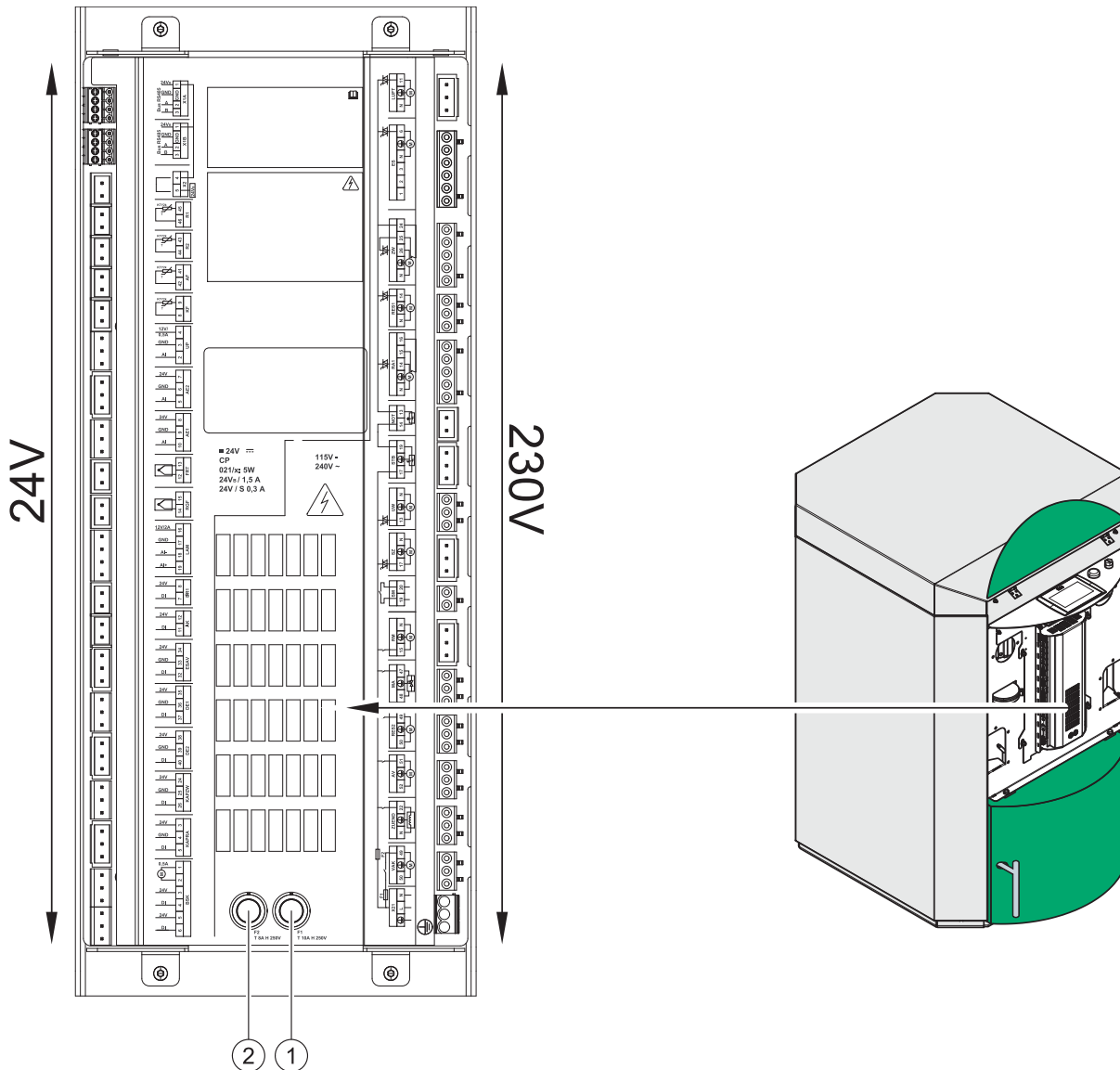

1	F1: Fuse T10A
2	F2: Fuse T8A

NOTICE

Damage of property

Fuses must be replaced only with fuses having the same current and voltage ratings.

7.1 Plugs on the boiler control unit

The designation of the plugs must correspond with the labeling of plug-in positions.

Designation of plug-in position		Voltage	Name of sensors, motors and pumps
X1A	3 2 GND 1	24 Volt	Operating display
X1B	3 2 GND 1	24 Volt	Heating controller (BUS)
X2	5 4	24 Volt	Power supply display
R1	46 45	24 Volt	Not used
R2	44 43	24 Volt	Not used
AF	42 41	24 Volt	Not used
KF	8 9	24 Volt	Boiler sensor
UP	2 3 4	24 Volt	Negative draft measuring
AE2	5 6 7	24 Volt	Level detection system
AE1	10 9 8	24 Volt	Not used
FRT	12 13	24 Volt	Combustion chamber temperature sensor
RGF	14 15	24 Volt	Flue gas temperature sensor (optional)
PWM	16 17	24 Volt	PWM for speed controlled high-efficiency pump
Analog IN	18 19	24 Volt	Not used
BR1	7 8	24 Volt	Burner contact
AK	11 12	24 Volt	Existing boiler (optional)
ESAV	32 33 34	24 Volt	End switch ash box
DE 1	37 36 35	24 Volt	Not used
DE 2	40 39 38	24 Volt	Not used
KAPZW	26 25 24	24 Volt	Capacitive sensor - hopper
KAPRA	5 4 3	24 Volt	Capacitive sensor - burner
BSK	6 5 4 3 2 1	24 Volt	Flame return gate
X21	PE L N	230 Volt	Power supply
VAK	56 PE 55	230 Volt	Vacuum turbine
ZUEND	N PE 22	230 Volt	Ignition
AV	52 PE 51	230 Volt	Motor ashbox
RES 2	54 PE 53	230 Volt	Not used
MA	48 PE 47	230 Volt	Magnetic valve (Cleaning nozzle, heat exchanger)
RM	15 PE N	230 Volt	Motor boiler cleaning device
SM	19 20	230 Volt	Relay fault signal (optional)
SZ	17 PE N	230 Volt	Flue gas fan
UW	13 PE N	230 Volt	Boiler controlled pump
STB	17 PE 19	230 Volt	Safety temperature sensor
NOT	41 43	230 Volt	Emergency stop heating
RA1	N PE 14 15 16	230 Volt	Fuel transport system
RES1	50 PE 49	230 Volt	Motor hopper - PES 36-56 only
ZW	N PE 26 25 24	230 Volt	Vibration motor

ES	1 2 3 N PE 6	230 Volt	Burner motor
LUFT	N PE 11	230 Volt	Burner fan

7.2 Wiring diagrams

The wiring diagrams for the boiler control unit provide detailed technical information for certified installers. Only certified installers or electricians under the direction of a certified installer may connect to the controller.

DANGER

Risk of electric shock
 Only an authorised installer may connect the pellet boiler to the power supply.
 Always disconnect / de-energize the power supply before working on the boiler.

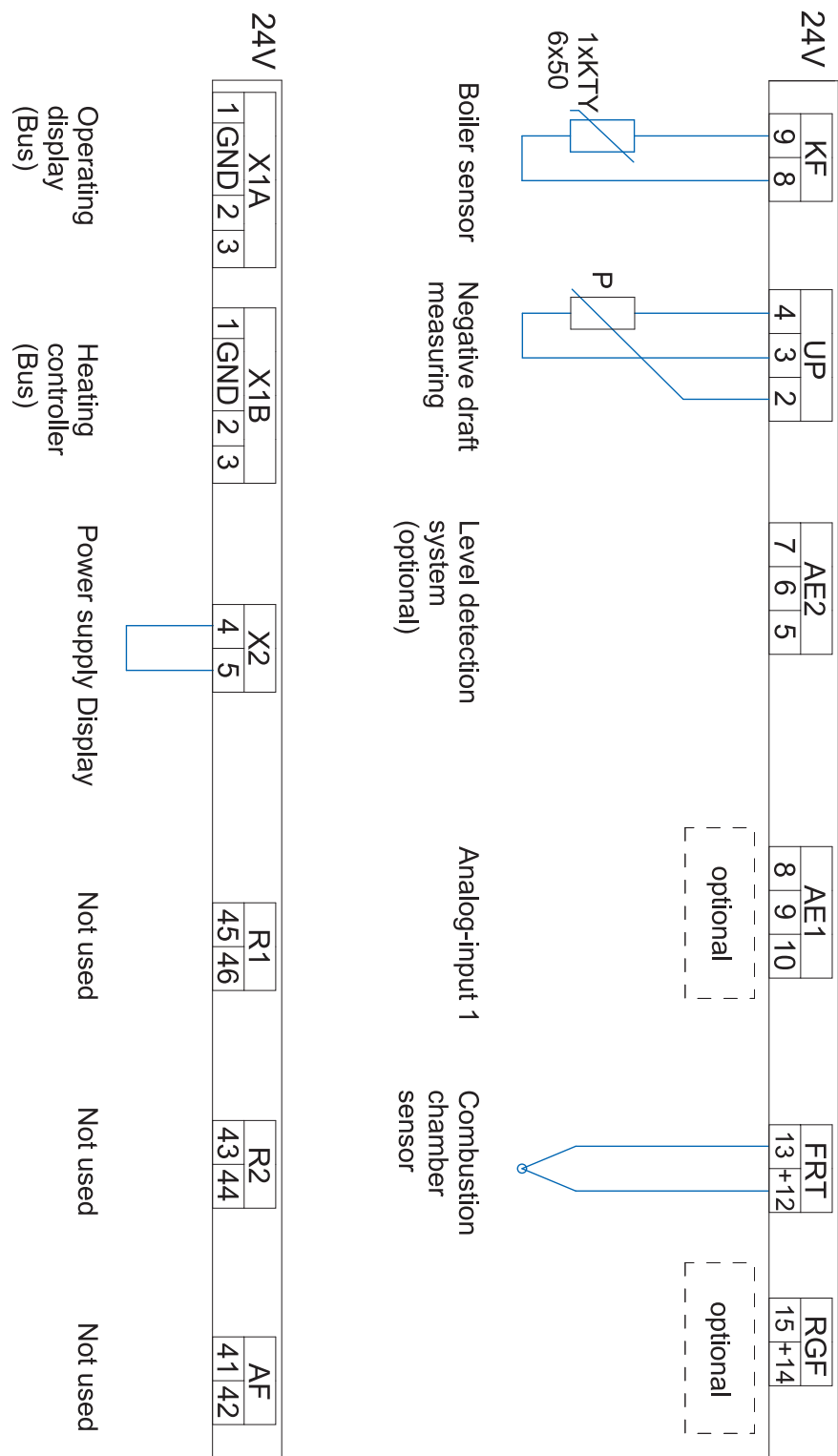

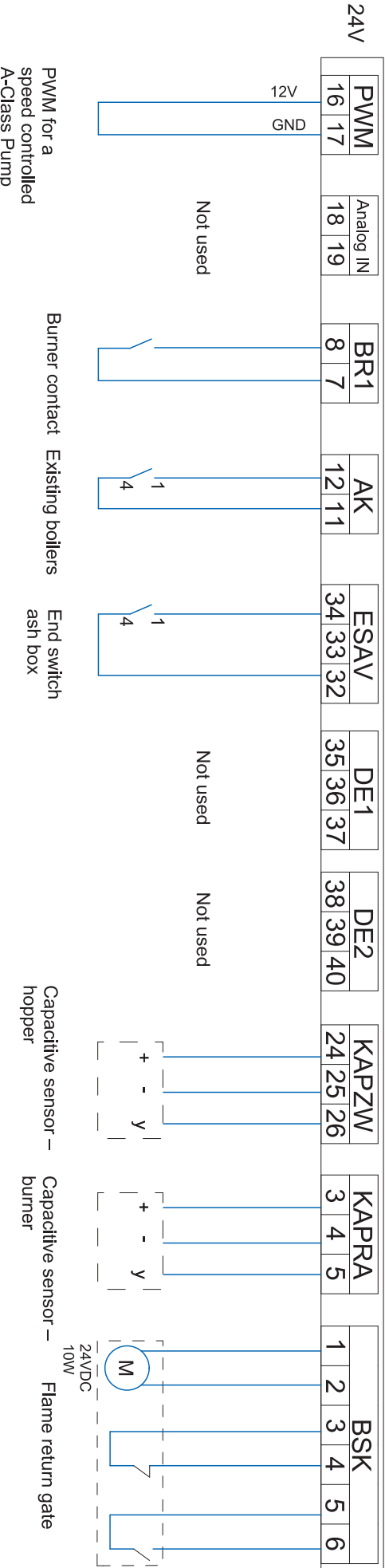

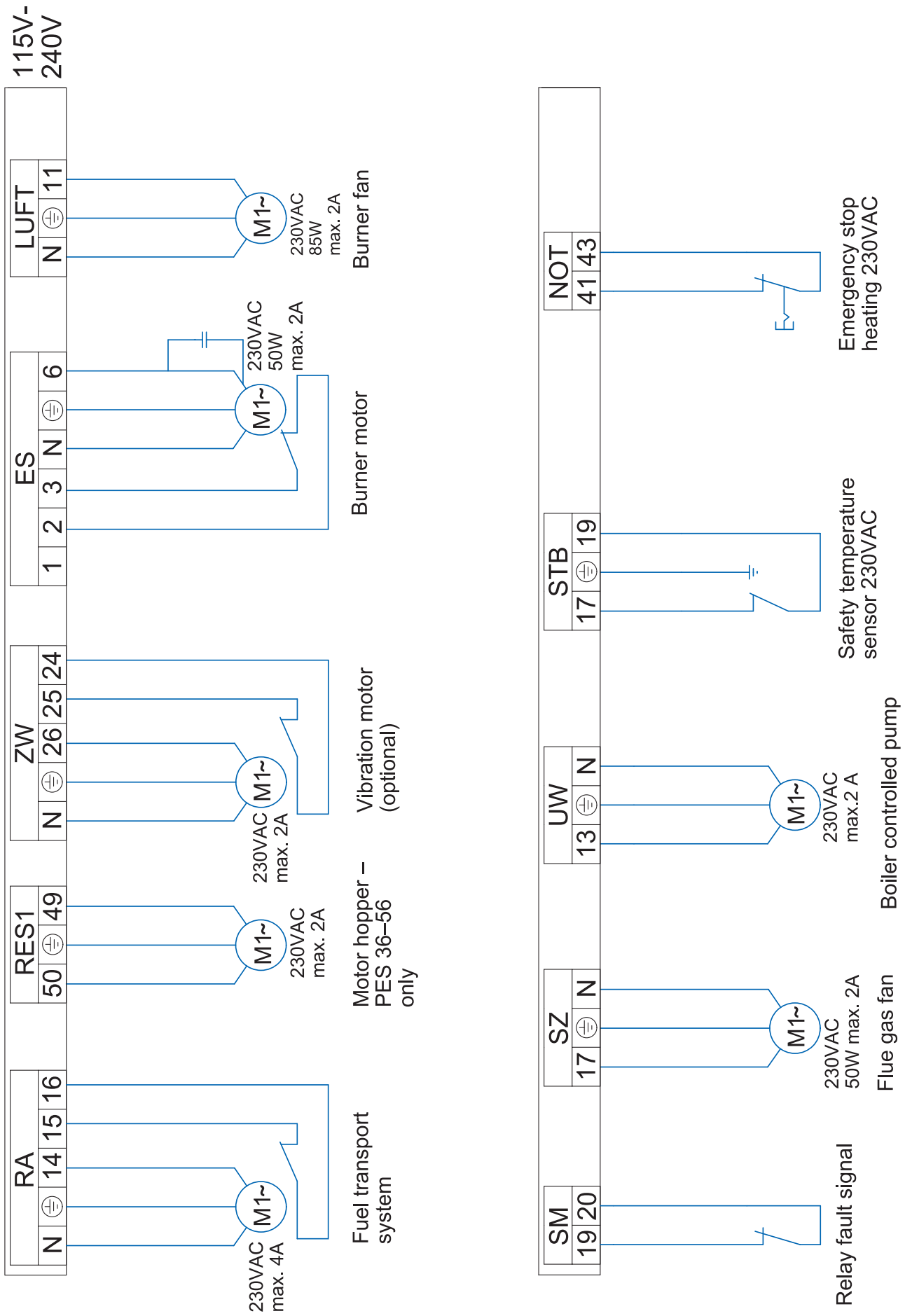

7.3 LED status boiler controller

Display	Description	Cause and remedy
red	Power supply present	—
red flashing	Error condition no communication possible	Check the software version Check the bus wiring Check the address
red / orange flashing	In the bus systems are devices using the same address	Change the address
orange	Power supply present Processor runs No bus communication	Check the software version Check the bus wiring Check the address
orange flashing	Firmware- update is in progress	—
green flashing	Initialization (Firmware boots)	If state is unchanged, software must be checked.
green	Operation Cyclic communication possible	—

7.4 Cable Routing

The cable routing and the connection of the motors and sensors is precisely described in the **Installation manual**.

8 The heating controller

The heating controller is in a wall box, which is in most cases installed nearby the heating circuit distributor. It is used to control the whole heat distribution system for example: domestic hot water, room temperature, solar system, accumulator, etc

It consists of a casing with an internal circuit board and terminals.

The cover plate of the casing is removable.



DANGER

Electric shock danger

Before opening, make sure that the whole heating system is powerless.

Note:

The heating controller is limited to 8 amps total current draw. Also, each output is rated at 2 amps max. Make sure that these values are not exceeded to avoid fuse failure.

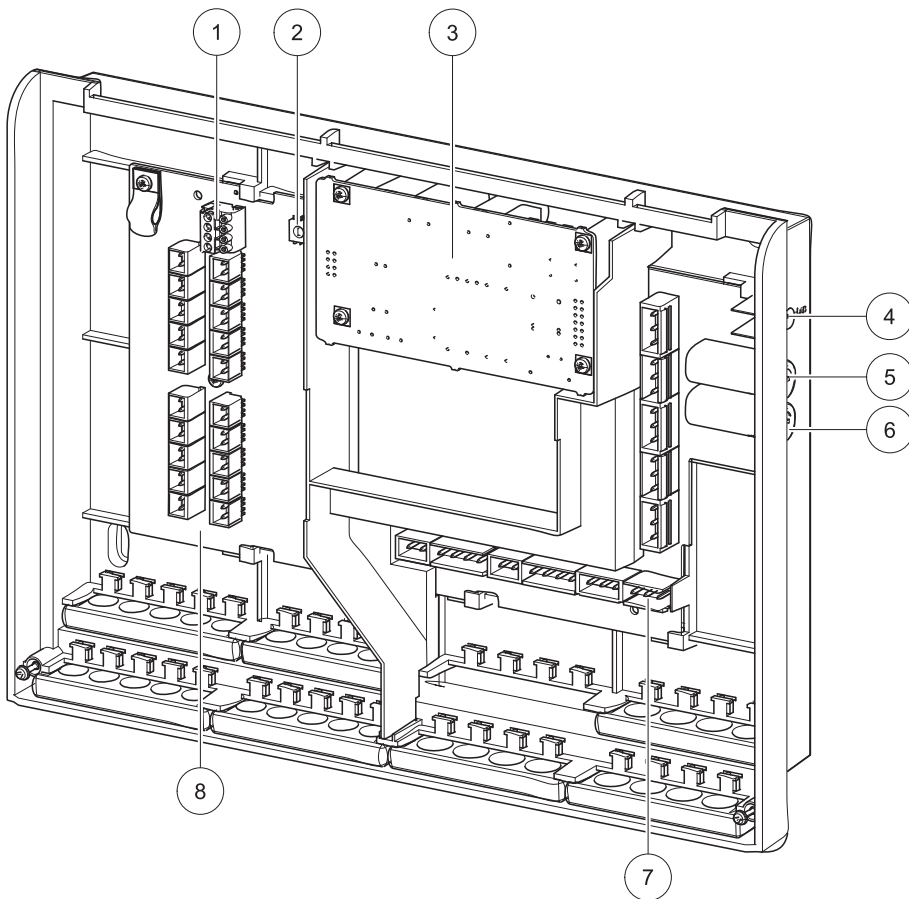

1	Bus connecting terminal RS485 A and B	5	Fuse 6,3 A (fast) for X31 and X33
2	Address switch	6	Fuse 8 A (slow-acting) limits the current consumption of the heating controller.
3	Slot for an optional power supply (The power supply is needed when the burner control CMP 06.2 is used. The power supply takes over the bus supply.)	7	Low voltage - area (dangerous voltage)
4	Status-LED	8	Extra low voltage (PELV)

8.1 LED status heating controller

Display	Description	Cause and remedy
red	Power supply present	—
red flashing	Error condition no communication possible	Check software version Check bus wiring
orange	Power supply present Processor runs no communication possible	Check bus wiring
green flashing	Initialization (Firmware boots)	—
green	Operation Cyclic communication possible	—

8.2 Connection plan

The Connection plan is a description of all the electrical connections from the Pelletronic heating controller:



DANGER

Only an authorised installer may install and connect the heating controller to the power supply.
Isolate the entire heating system from the power supply before starting work on the heating controller.

NOTICE

Boiler sensor + outside sensor must be connected on the first heating controller!

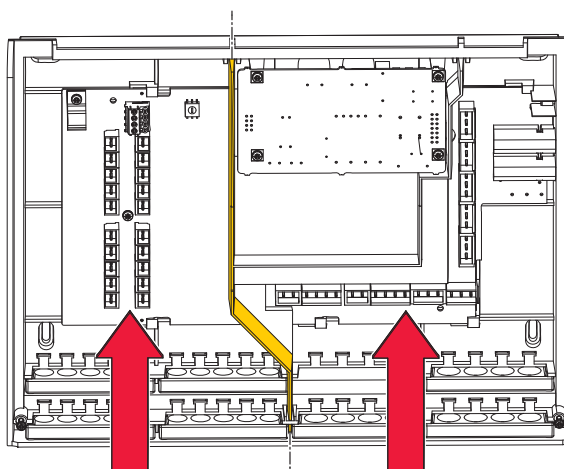

Terminals extra-low voltage zone		Terminals low voltage zone - 120VAC	
X1A	Bus wiring - Bus RS485	Burner demand 1 - BRanf 1	X22
X1B	Bus wiring - Bus RS485	Mixer HK1 opening - M1	X23 - 13/N
X2	Outdoor sensor - AF	Mixer HK1 closing - M1	X23 - 23/N
X3	Boiler sensor - KF	Burner demand 2 - BRanf 2 (Potential free contact)	X24
X4	Flow sensor HK1 - VL1	Mixer HK2 opening - M2	X25 - 13/N
X5	Flow sensor HK2 - VL2	Mixer HK2 closing - M2	X25 - 23/N
X6	DHW sensor - WW	Heating circuit pump - HK1	X26
X7	AC upper sensor - PO	Heating circuit pump - HK2	X27
X8	AC middle sensor - PM	Solar pump 2 - Sol P2	X28
X9	AC lower sensor 1 - SPU1	Return pump - Heat main pump - ZP	X29
X10	AC lower sensor 2 - SPU2	Domestic hot water - WW	X30
X11	Solar pump 1 A-class	Solar pump 1- Sol P1	X31
X12	Reserve - S3	Accumulator pump - PLP	X32
X13	Reserve - S2	Power supply 115V - 240V-	X33
X14	Return sensor - ZIRK		
X15	Collector sensor - KOLL		
X16	Solar energy Flow - VWMZ		

X17	Solar energy Return - RWMZ		
X18	Reserve - S1		
X19	Flow rate 24V - Z_IN		
X20	Reserve - 0-10V		
X21	Solar pump 2 A-class or Accumulator pump A-class		

Terminals extra-low voltage zone				
	X1A	Bus wiring - Bus RS485		
	X1B	Bus wiring - Bus RS485		
X2	Outdoor sensor - AF		X12	Reserve - S3
X3	Boiler sensor - KF		X13	Reserve - S2
X4	Flow sensor HK1 - VL1		X14	Return sensor - ZIRK
X5	Flow sensor HK2 - VL2		X15	Collector sensor - KOLL
X6	DHW sensor - WW		X16	Solar energy Flow - VWMZ
X7	AC upper sensor - PO		X17	Solar energy Return- RWMZ
X8	AC middle sensor - PM		X18	Reserve - S1
X9	AC lower sensor 1 - SPU1		X19	Flow rate 24V - Z_IN
X10	AC lower sensor 2 - SPU2		X20	Reserve - 0-10V
X11	Solar pump 1 A-class		X21	Solar pump 2 A-class or Accumulator pump A-class
	X34		Jumper	

Terminals low voltage zone - 120VAC				
X32	Accumulator pump - PLP			
X31	Solar pump 1- Sol P1			
X30	Domestic hot water - WW			
X25 - 23/N	Mixer HK2 closing - M2		X33	Power supply 115V - 240V~
X25 - 13/N	Mixer HK2 opening - M2		X29	Return pump - Heat main pump - ZP
X24	Burner demand 2 - BRanf 2 (Potential free contact)		X28	Solar pump 2 - Sol P2
X23 - 23/N	Mixer HK1 closing - M1			
X23 - 13/N	Mixer HK1 opening - M1			
X22	Burner demand - BRanf 1			
	X26		Heating circuit pump - HK1	
	X27	Heating circuit pump - HK2		

Electrical wiring diagrams heating controller

The wiring diagrams are also located on the inside of the cover of the heating controller. Be aware of the instructions and diagrams illustrated there.

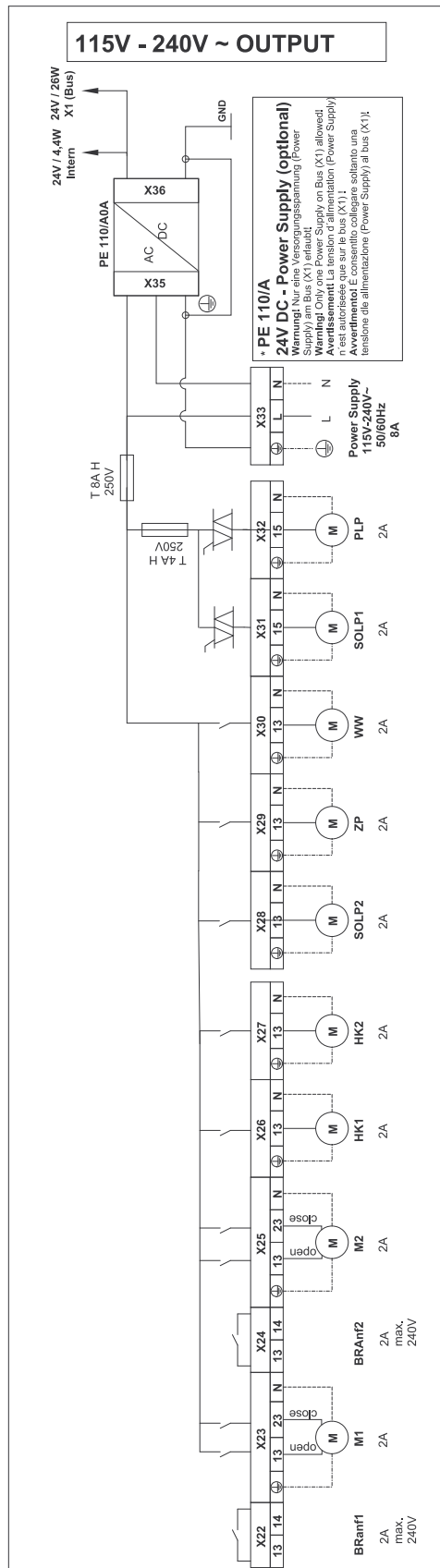
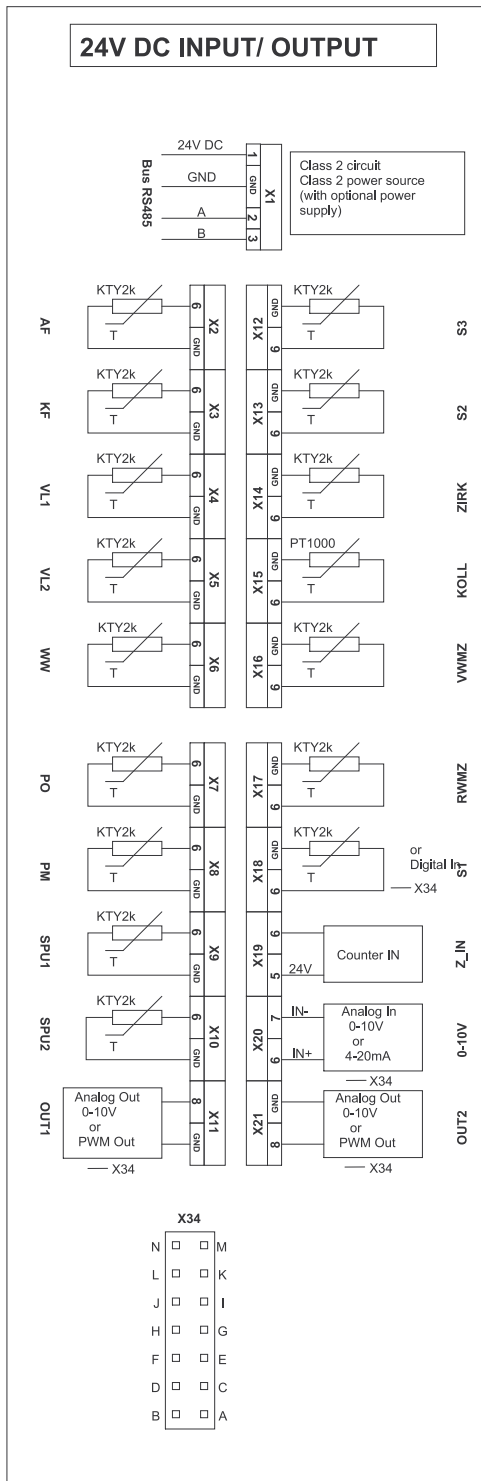

8.2.1 Jumper X34 for analog voltage outputs X11 (OUT1) and X21 (OUT2)

The different types of high-efficiency pumps: Analog pumps with 0-10 V control and PWM pumps with 24V. For each type of pump you have to adjust the signal at the heating controller. The plug connector X34 is for the Jumper-settings. Use a jumper with a grid dimension of 1 inch. The terminals X11 and X21 can receive or export a different signal depending on the jumper position.

Note:

When using PWM-pumps for a voltage up to 15V, adapter-cables must be connected at the slots X11 and X12. These cables limit the output voltage from 24V to 15V.

Jumpersettings X34:

The male connector X34 serves for jumper-adjustments. Please use jumper with a contact spacing of 1 inch (included in delivery of heating controller)

High-efficiency pump with external control function	Terminal	Designation	Function	Plug connector	Position
Solar pump 1	X11	Out 1	PWM Out Analog Out 0-10V	A-B and C-D A-B and C-D	0 X
Solar pump 2 (or accumulator pump)	X21	Out 2	PWM Out Analog Out 0-10V	E-F and G-H E-F and G-H	0 X

0.... Jumper is not set, pins open.
X.... Jumper is set, pins closed.

8.3 Rules of wiring for micronetwork with 1,2 or more heating controllers

The boiler controller supplies the touch operating device and up to two remote controls.

- The order of devices in the bus-wiring is free. The station-numbers for the heating controller and the digital remote controls have to be assigned **uninterrupted**.
- The number of heating controllers is independent from the numbers of the digital remote controls and independent from the numbers of boiler controllers.
- A **double allocation** is not acceptable.
- The **maximum limit of bus-participants is 16**.
- The maximum length of a bus-cable is 200 metres.
- The maximum cable-length depends on:
 - A solid **point-to-point topology** allows the fullmax. length.
 - A **star-topology** does not allow the max. length.
 - We recommend a **twisted-pair cable**, especially for long cables (e.g. in buildings) and if the cable runs parallel to other cables.
 - Correct bus-connection resistance, which is always existing on boiler operating device.
 For long cables or communication problems occur, a additional resistor with 120 Ohm has to be clamped **between wire A and B** at the last bus-participant.

NOTICE

When controlling a cascade-system, a bridge must be installed at **boiler controller port X2**.

8.4 Wiring diagrams

Wiring diagram with:

- 1x Boiler controller FA
- 1x Heating controller Pelletronic
- 1x Touch operating device (Master)
- 1x Touch remote control (Slave)
- 1x Remote controll with LED

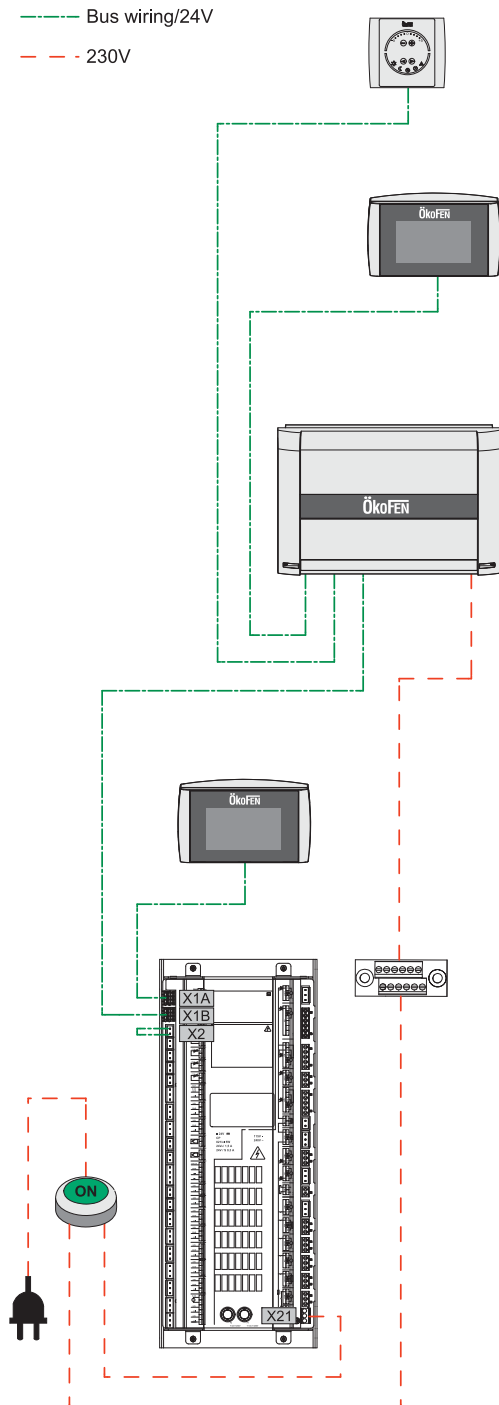

Note:

You find more detailed information about wiring in chapter 8.3 Rules of wiring for micronetwork with 1,2 or more heating controllers, page 25

Wiring diagram with:

- 3x Boiler controller FA
- 3x Heating controller Pelletronic
- 1x Touch operating device (Master)
- 4x Touch remote control (Slave)
- 2x remote controll with LED

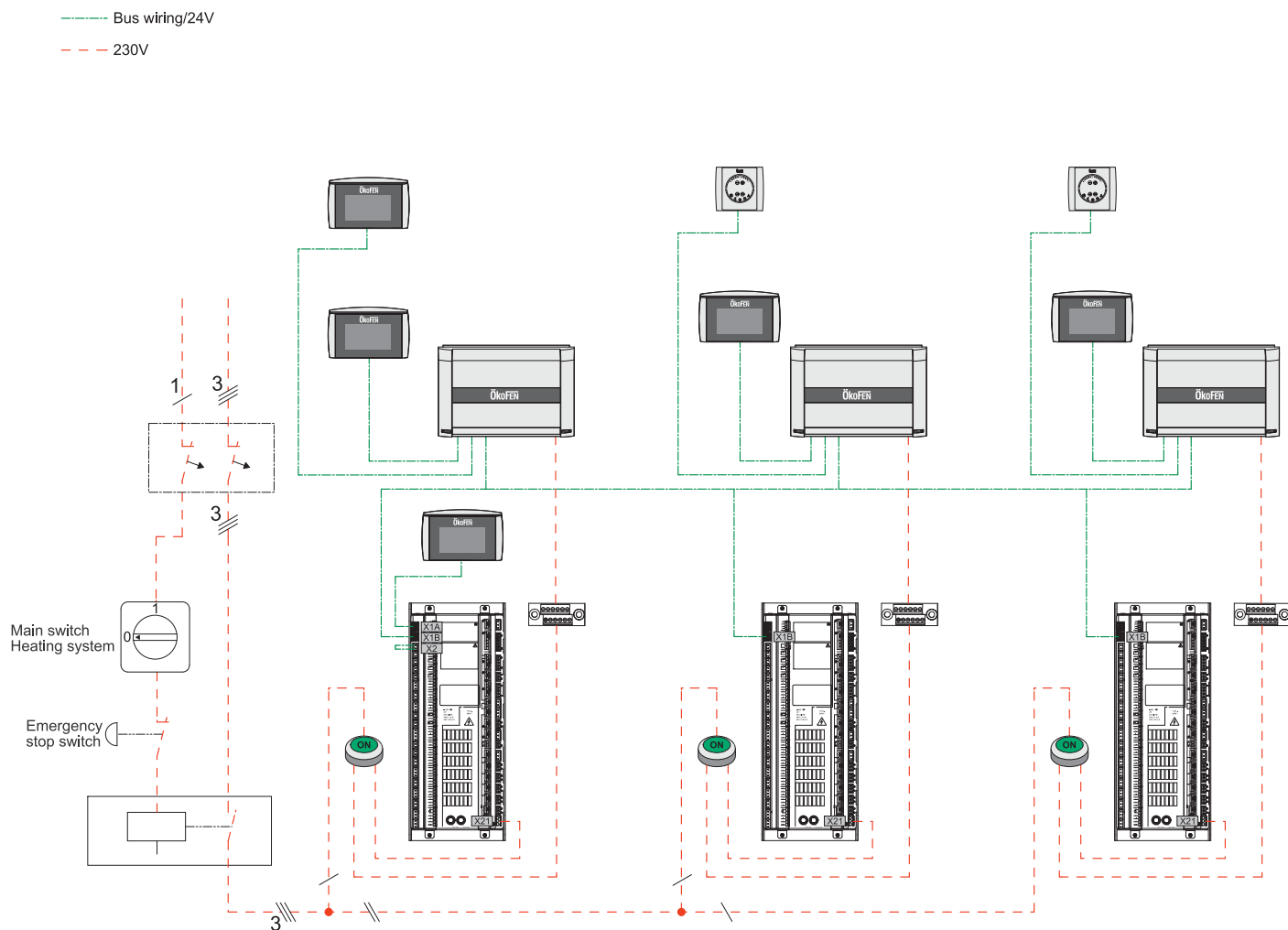

Note:

You find more detailed information about wiring in chapter 8.3 Rules of wiring for micronetwork with 1,2 or more heating controllers, page 25

8.5 Assembly and disassembly of the heating controller circuit board

You can take off the circuit board of the heating controller, without filtering out the inputs and outputs.

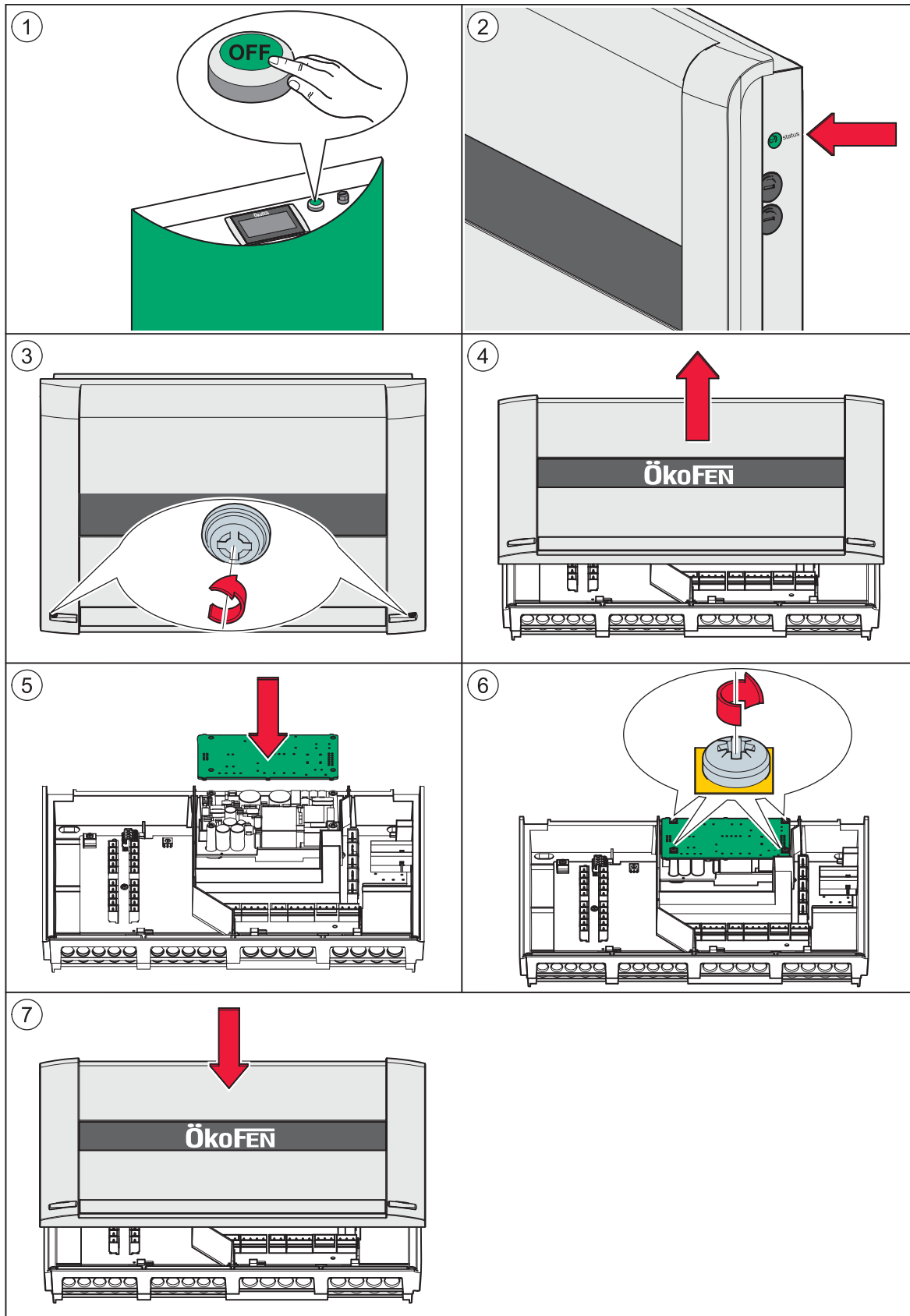

Note:

Image 2: Control with the status of the LED that the heating controller is electroless.

1. Make the complete heating system powerless.

NOTICE

Electrostatic discharge damage

Before starting work, touch a grounded object to avoid damage of circuit board by electrostatic charging.

2. Open the cover plate of the heating controller.
3. Disconnect all plugs from the circuit board. Leave the plugs with the wiring in the casing.
4. Disassembly from the power supply (optional)
5. Disassembly the circuit board from the heating controller.

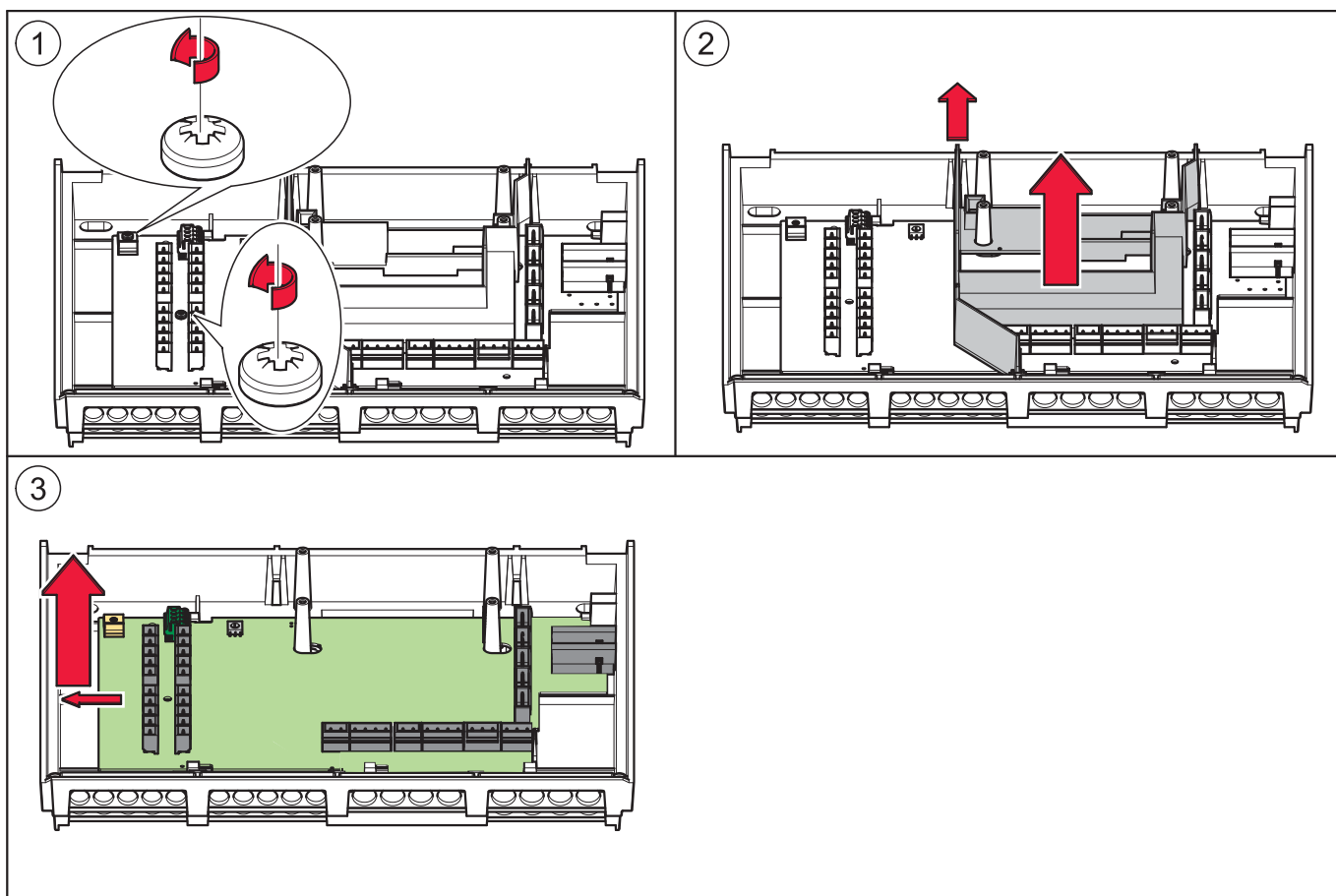

6. The installation of a new circuit board occurs in reverse order.

8.6 Cable specification Pelletronic Touch

Power supply	K 02	X33	YML-J	3x1	x
OUTPUTS see on wiring diagram on the front side					
Function - Shortcut	Cable	Pin I/O BOX	Cable type	Section	Max Ampere
Burner contact 1 - BRanf 1	K 03	X22	YML-J	3x0.75	2A
Mixer HK1 OPEN - M1	K 12	X23 - 13/N	YML-J	3x0.75	2A
Mixer HK1 CLOSED - M1	K 12	X23 - 23/N	YML-J	3x0.75	2A
Burner contact 2 - BRanf 2 (Potential free contact)	K 30	X24	YML-J	3x0.75	2A
Mixer HK2 OPEN - M2	K 13	X25 - 13/N	YML-J	3x0.75	2A
Mixer HK2 CLOSED - M2	K 13	X25 - 23/N	YML-J	3x0.75	2A
Heating circuit pump - HK1	K 14	X26	YML-J	3x0.75	2A
Heating circuit pump - HK2	K 15	X27	YML-J	3x0.75	2A
Solar pump 1 - Sol P1	K 16	X31	YML-J	3x0.75	2A
Return pump - Heat main pump - ZP	K 29	X29	YML-J	3x0.75	2A
Domestic hot water pump - WW	K 21	X30	YML-J	3x0.75	2A
Solar pump 2 - Sol P2	K 23	X28	YML-J	3x0.75	2A
Accumulator pump - PLP	K 05	X32	YML-J	3x0.75	2A
Bus wiring - Bus RS485	K 01	X1A	YSLCY-0Z	4x0.75	x
Bus wiring - Bus RS485		X1B	YSLCY-0Z	4x0.75	x
Solar high-efficiency pump 1	K 28	X11	YML	2x0.75	x
Solar high-efficiency pump 2 or Accumulator high-efficiency pump	K 71	X21	YML	2x0.75	x
INPUTS see on wiring diagram on the front side					
Function - Shortcut	Cable	Pin I/O BOX	Cable type	Section	Max Ampere
Outdoor sensor - AF	K 09	X2	YML	2x0.75	KTY 2k
Boiler sensor - KF	K 04	X3	YML	2x0.75	KTY 2k
Flow sensor HK1 - VL1	K 10	X4	YML	2x0.75	KTY 2k
Flow sensor HK2 - VL2	K 11	X5	YML	2x0.75	KTY 2k
DHW sensor - WW	K 19	X6	YML	2x0.75	KTY 2k
AC upper sensor (TPO) - PO	K 18	X7	YML	2x0.75	KTY 2k
AC middle sensor (TPM) - PM	K 17	X8	YML	2x0.75	KTY 2k
AC lower sensor 1 - SPU1	K 20	X9	YML	2x0.75	KTY 2k
AC lower sensor 2 - SPU2	K 22	X10	YML	2x0.75	KTY 2k
Reserve sensor - S3		X12	YML	2x0.75	KTY 2k
Sensor existing boiler - S2		X13	YML	2x0.75	KTY 2k
Sensor return pump - ZIRK	K 29	X14	YML	2x0.75	KTY 2k

Collector sensor - KOLL	K 08	X15	YML	2x0.75	PT 1000
Solar energy Flow - VWMZ	K 25	X16	YML	2x0.75	KTY 2k
Solar energy Return - RWMZ	K 26	X17	YML	2x0.75	KTY 2k
Sensor Reserve - S1		X18	YML	2x0.75	KTY 2k/Dig I
Flow rate 24V - Z_IN		X19	YML	2x0.75	x
Reserve - 0-10V		X20	YML-J	3x1	x

8.7 Sensor values

Values of resistance and thermic voltage of the different sensores can be found in the following table:

Temperature [°C]	Resistance temperature sensor [Ω]		thermical voltage [μV]
	PT 1000 (collector sensor)	KTY (heating sensor)	NiCr Ni (combustion chamber sensor)
-20	922	1396	-777
-15	941	1431	-588
-10	961	1499	-392
-5	980	1562	-196
0	1000	1630	0
5	1020	1700	-199
10	1039	1772	397
15	1058	1846	596
20	1078	1922	798
25	1097	2000	997
30	1117	2080	1203
40	1155	2245	1611
50	1194	2418	2022
60	1232	2599	2436
70	1271	2788	2850
80	1309	2984	3266
90	1347	3188	3681
100	1385	3400	4095

8.8 Hydraulic connecting diagrams

8.8.1 Hydraulic connecting diagrams Pelletronic Touch

8.8.1.1 Diagram 1

1 Boiler Pellematic - 1 Accumulator Pellaqua - 2 Heating circuits - 1 Solar circuit

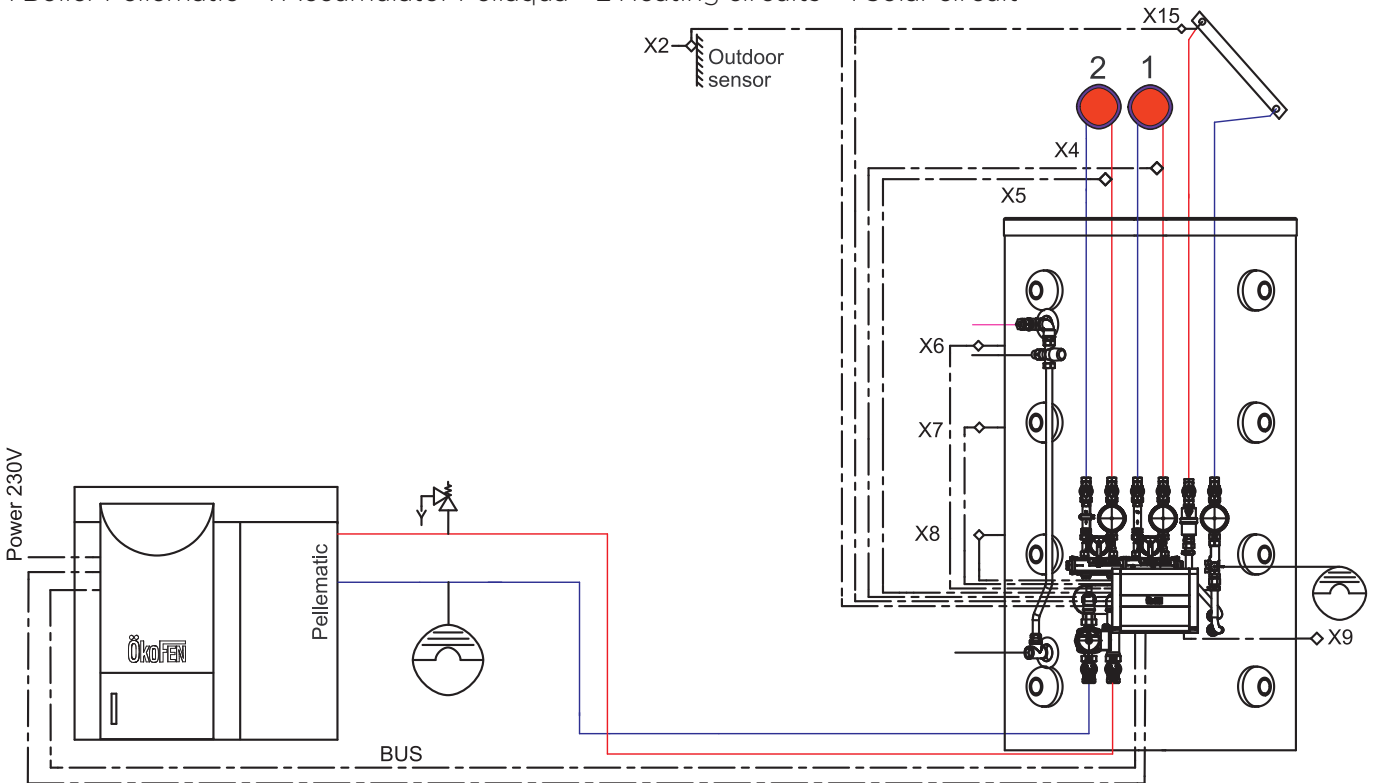

8.8.1.2 Diagram 2

1 Boiler Pellematic - 1 DHW Accumulator - 2 Heating circuits - 1 Solar circuit

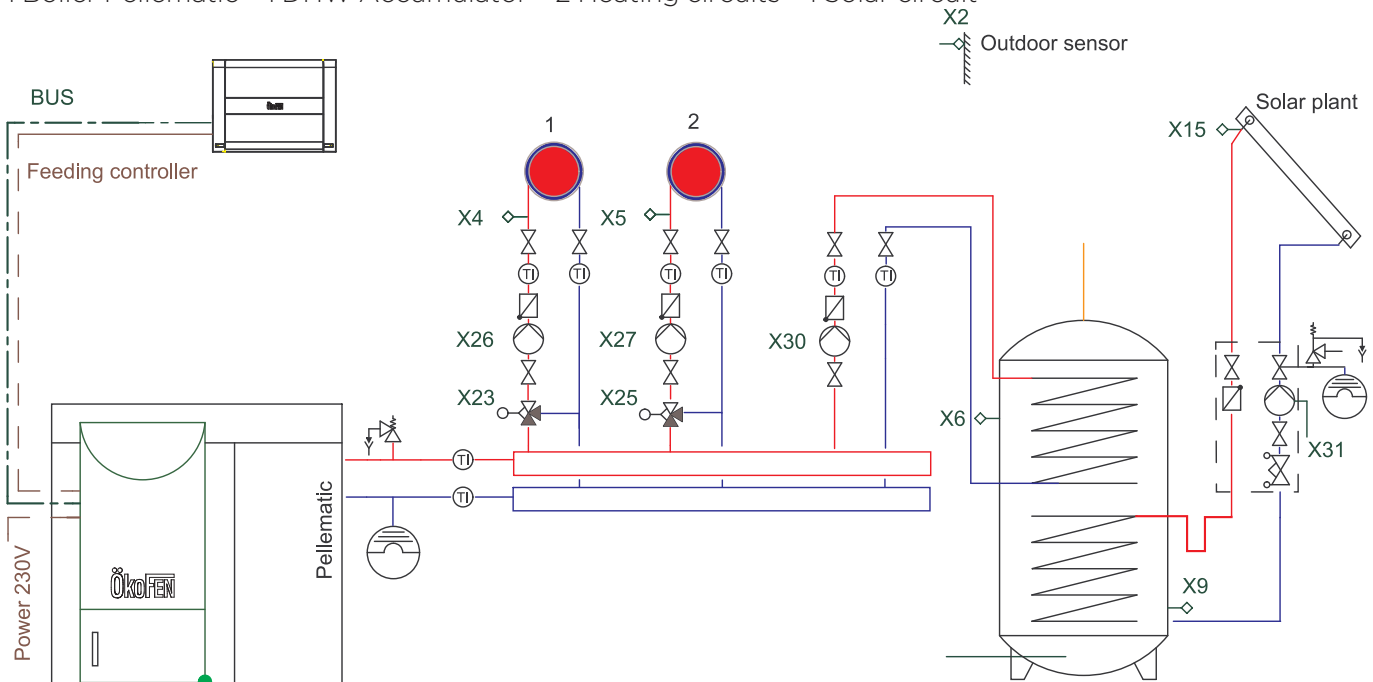

8.8.1.3 Diagram 3

1 Boiler Pellematic - 1 Accumulator Pellaqua - 2 Heating circuits - 1 Fresh water module - 1 Solar circuit

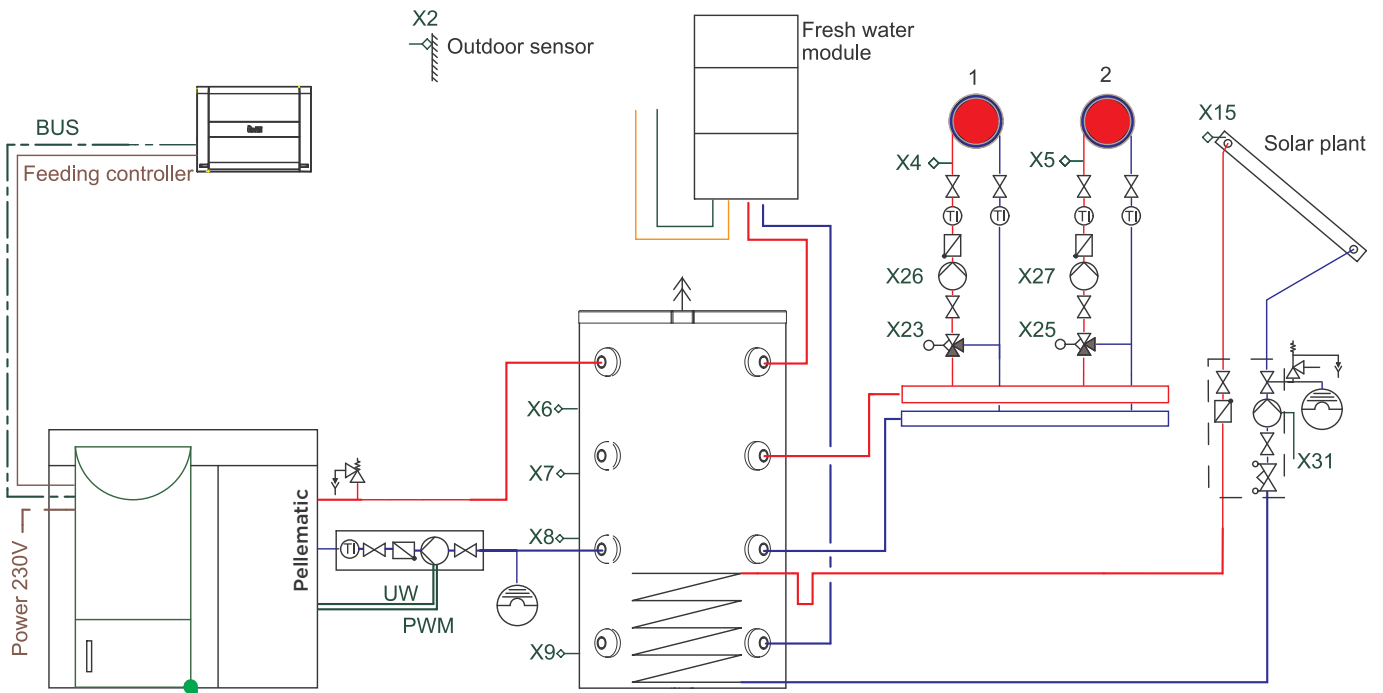

8.8.1.4 Diagram 4

1 Boiler Pellematic - 2 Accumulators Pellaqua - 2 Fresh water module - 4 Heating circuits - 1 Solar circuit

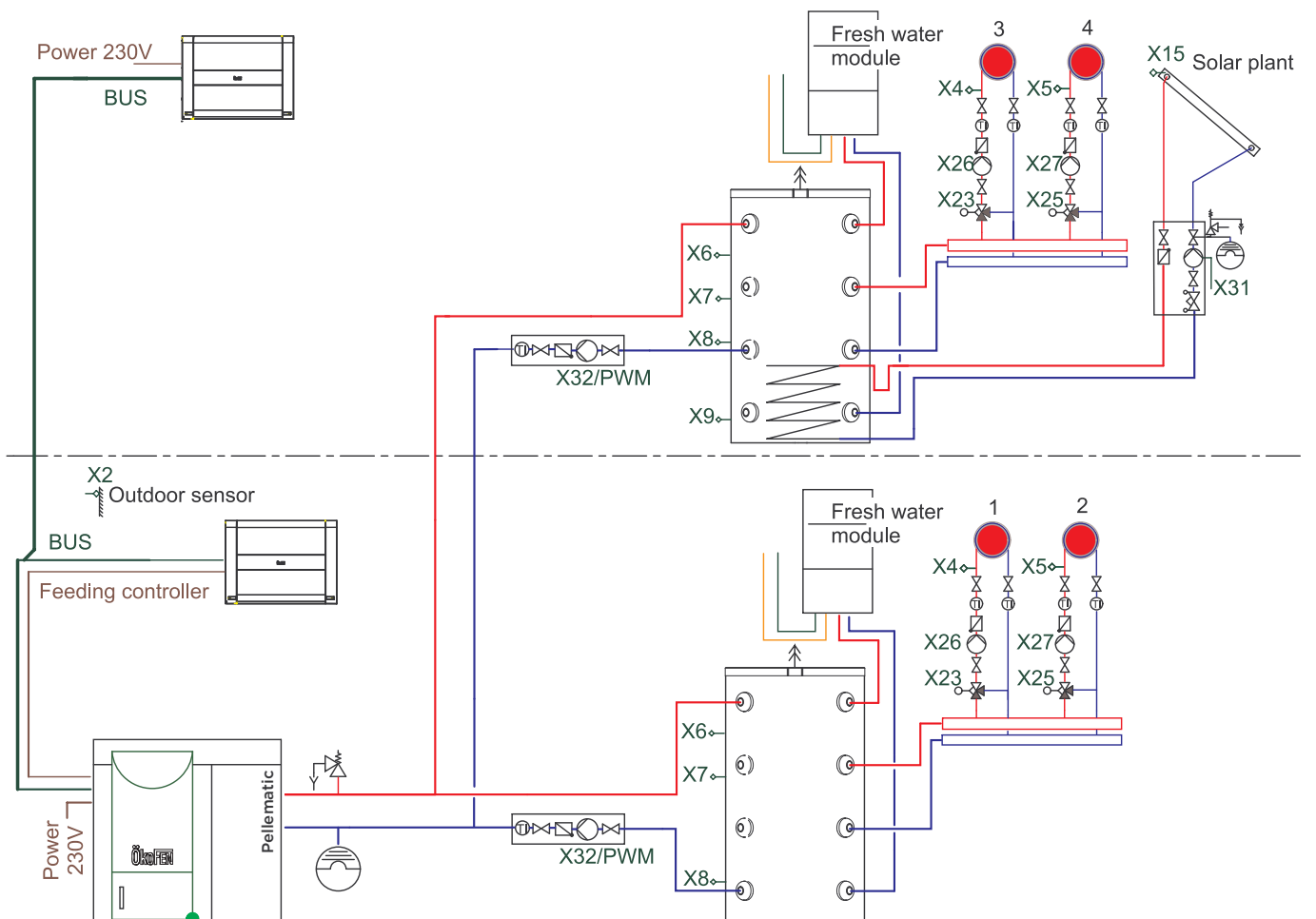

8.8.1.5 Diagram 5

1 Boiler Pellematic – 1 Accumulator Pellaqua – 1 Fresh water module – 4 Heating circuits – 1 Solar circuit – 1 DHW Accumulator

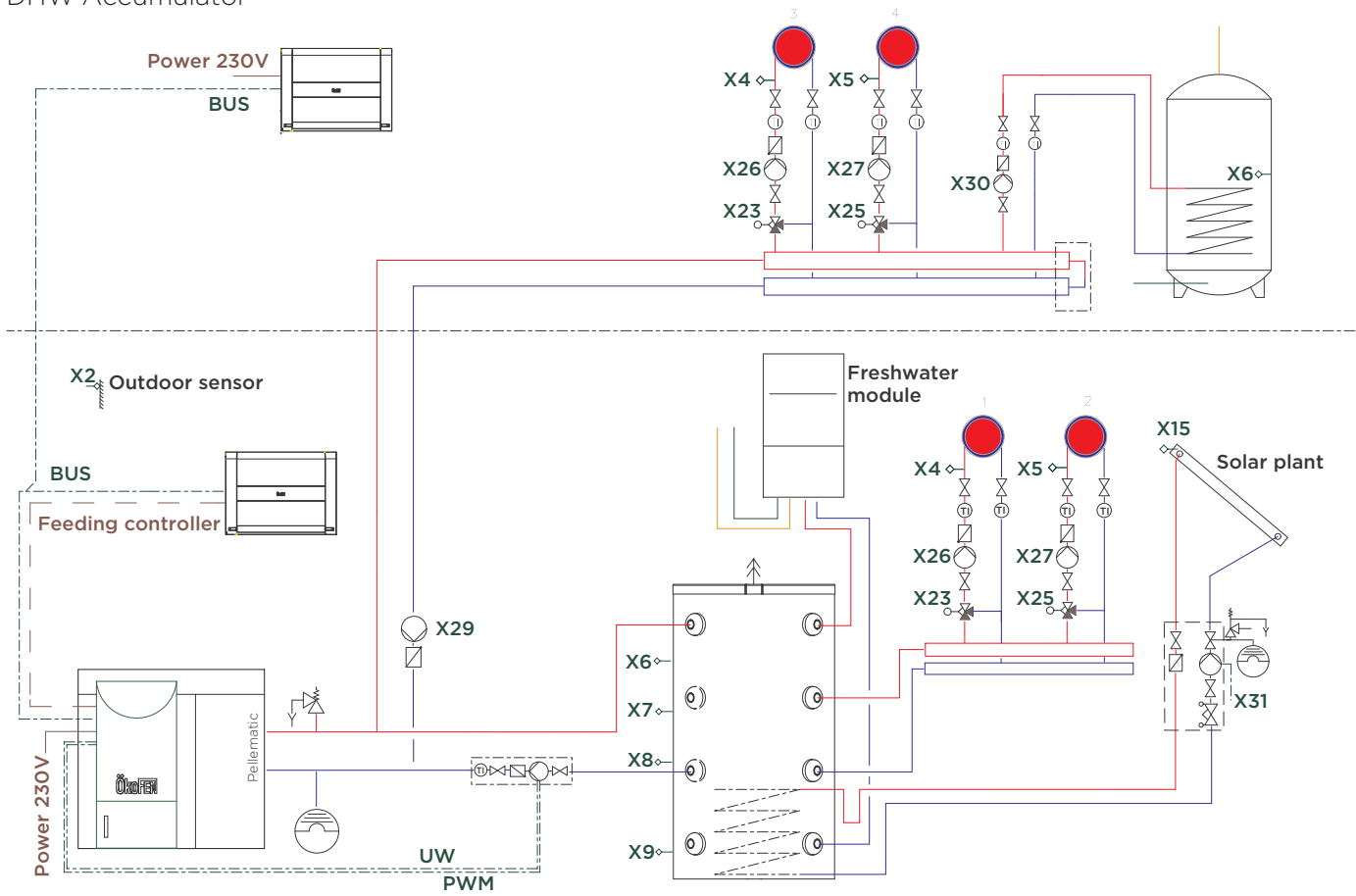

8.8.1.6 Diagram 6

1 Boiler Pellematic – 1 Accumulator Pellaqua – 1 DHW Accumulator – 2 Heating circuits – 2 Solar circuits

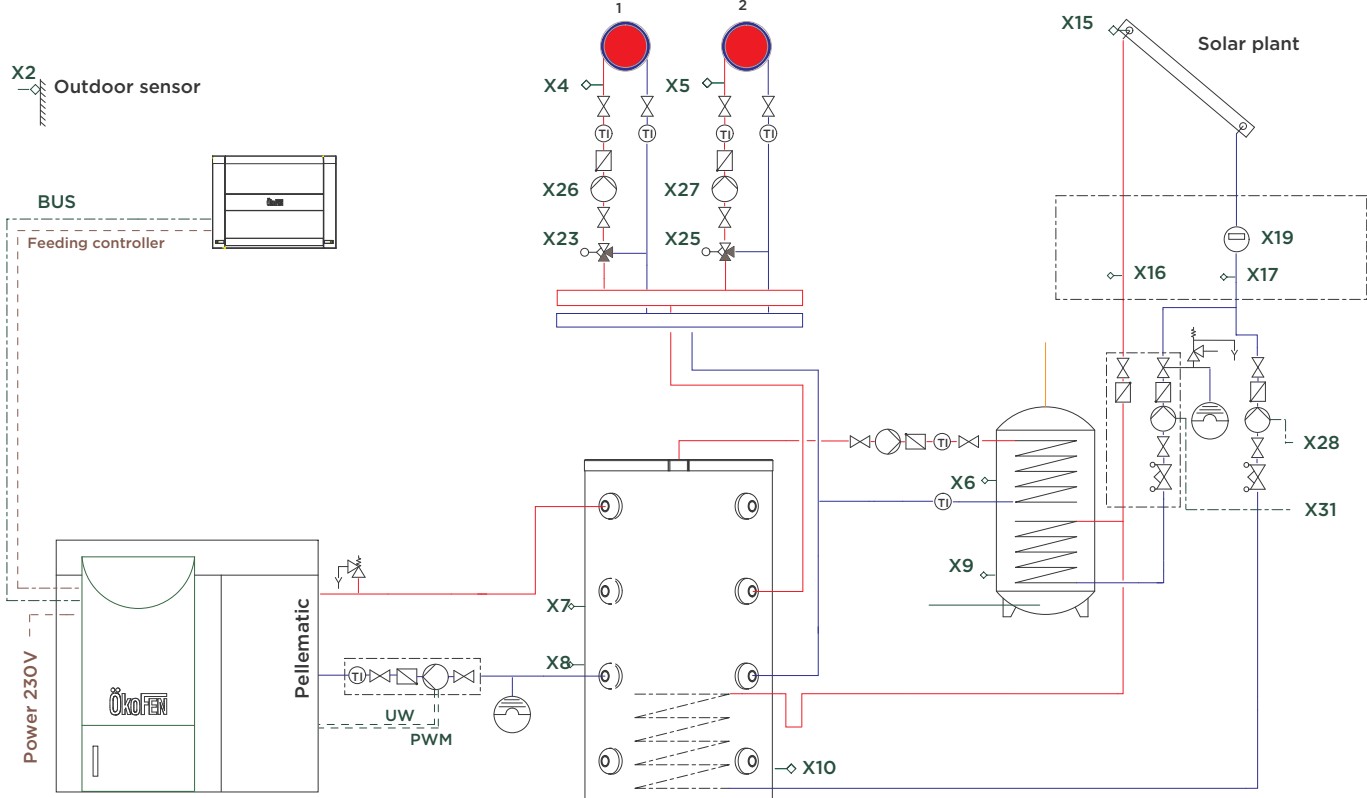

8.8.1.7 Diagram 7

1 Boiler Pellematic - 1 Accumulator Pellaqua - 2 Heating circuits - 1 Layer charge modul

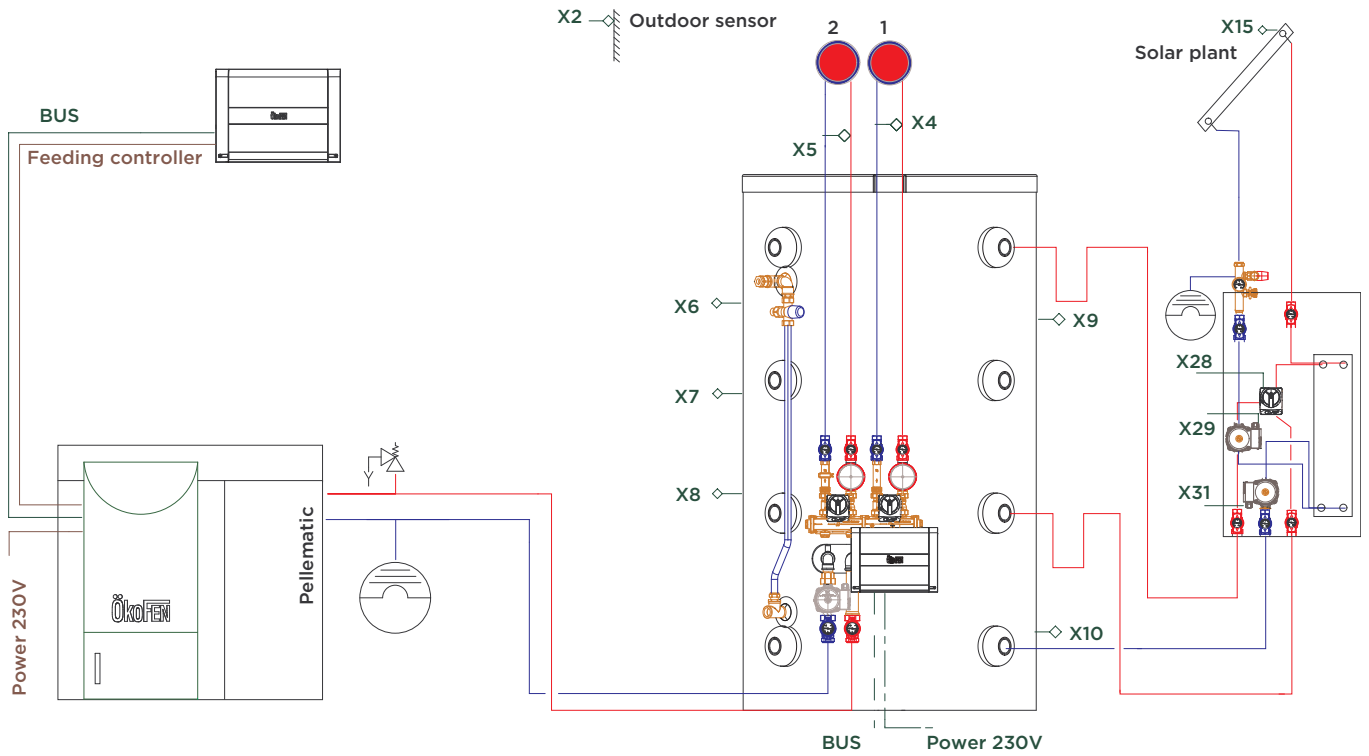

8.8.1.8 Diagram 8

1 Boiler Pellematic - 1 Accumulator Pellaqua - 2 Heating circuits - Solar layer device

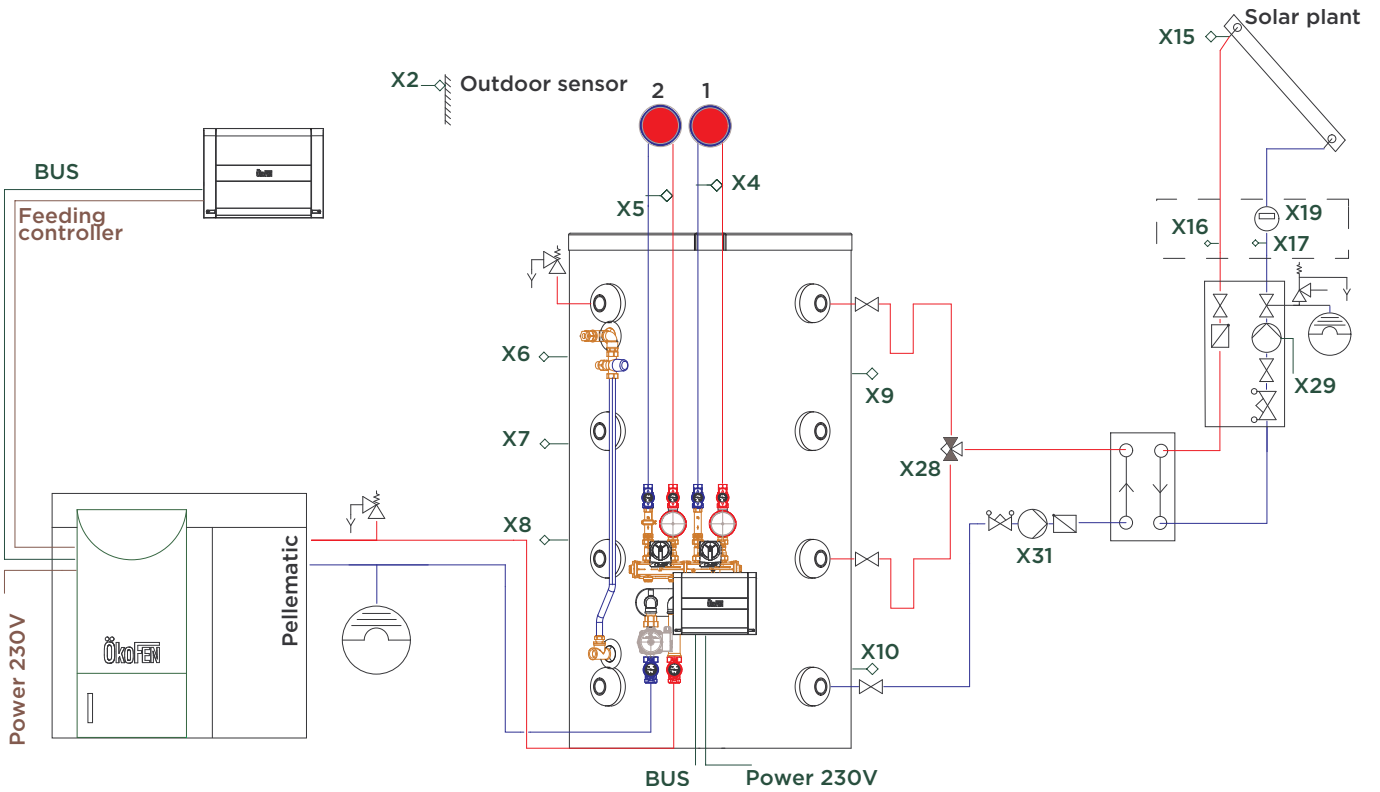

8.8.1.9 Diagram 9

1 Boiler Pellematic - 1 Accumulator Pellaqua - 2 Heating circuits - 1 Heat main pump

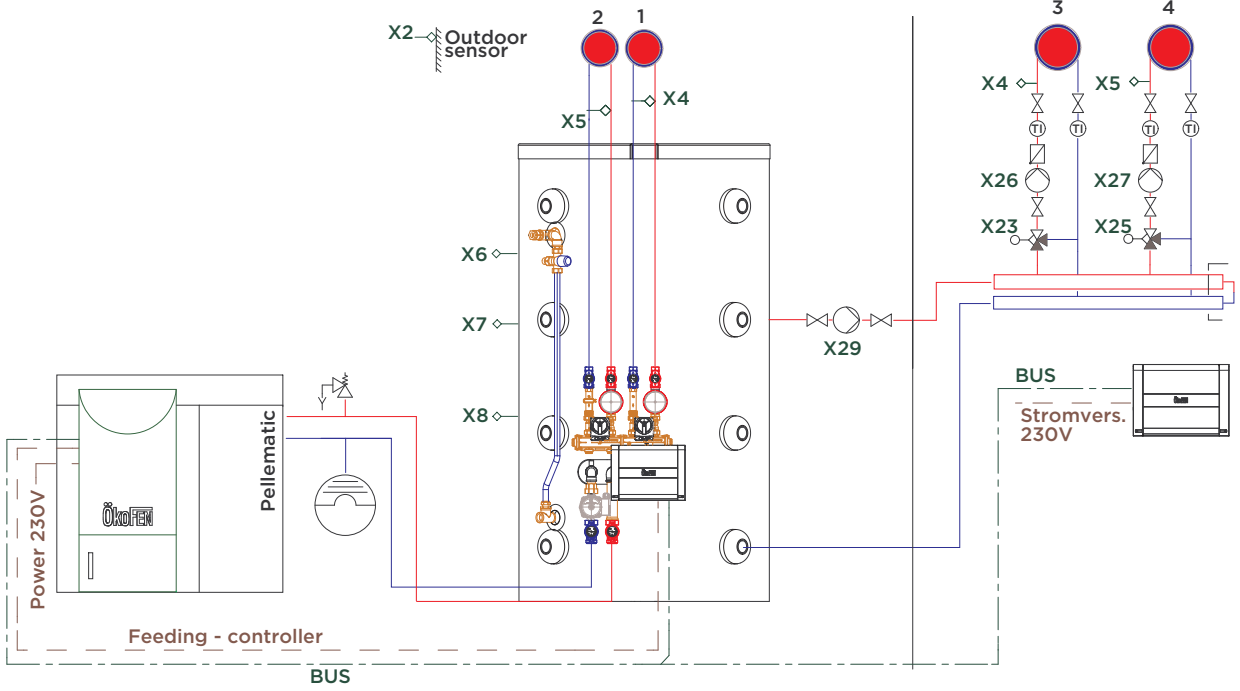

8.8.1.10 Diagram 10

2 Boilers Pellematic - 1 Hydraulic separator - 4 Heating circuits

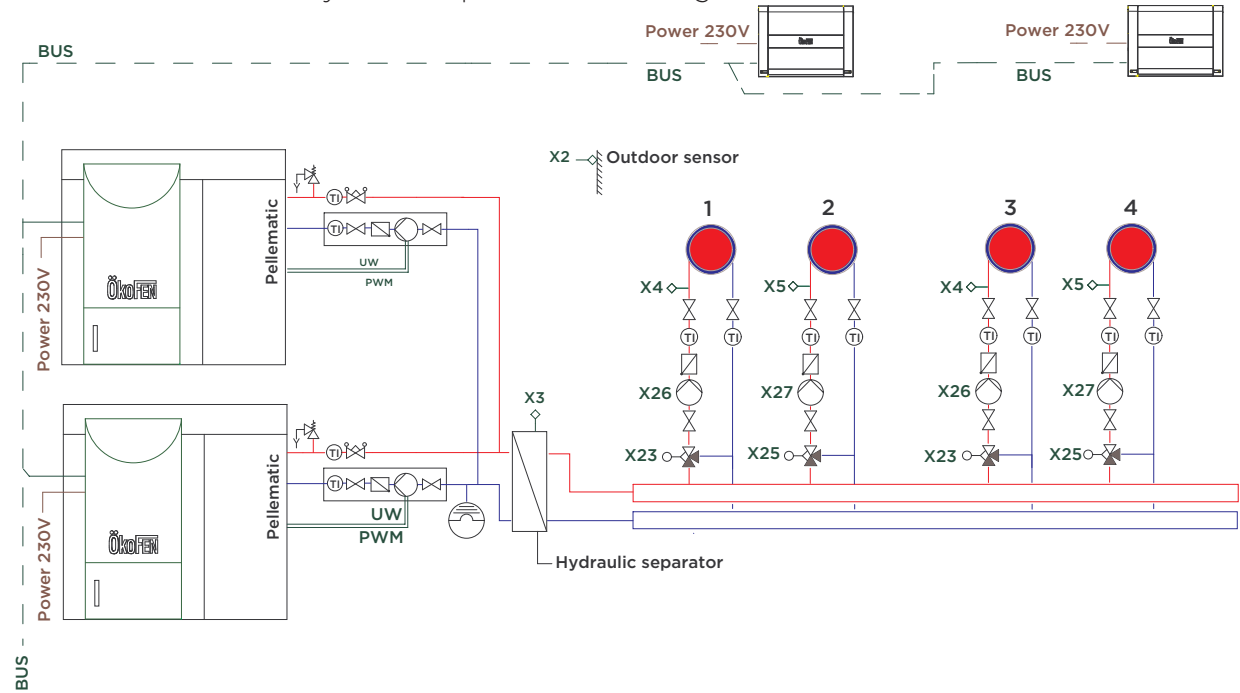

8.8.1.11 Diagram 11

2 Boilers Pellematic – 1 Accumulator Pellaqua – 1 Fresh water module – 2 Heating circuits

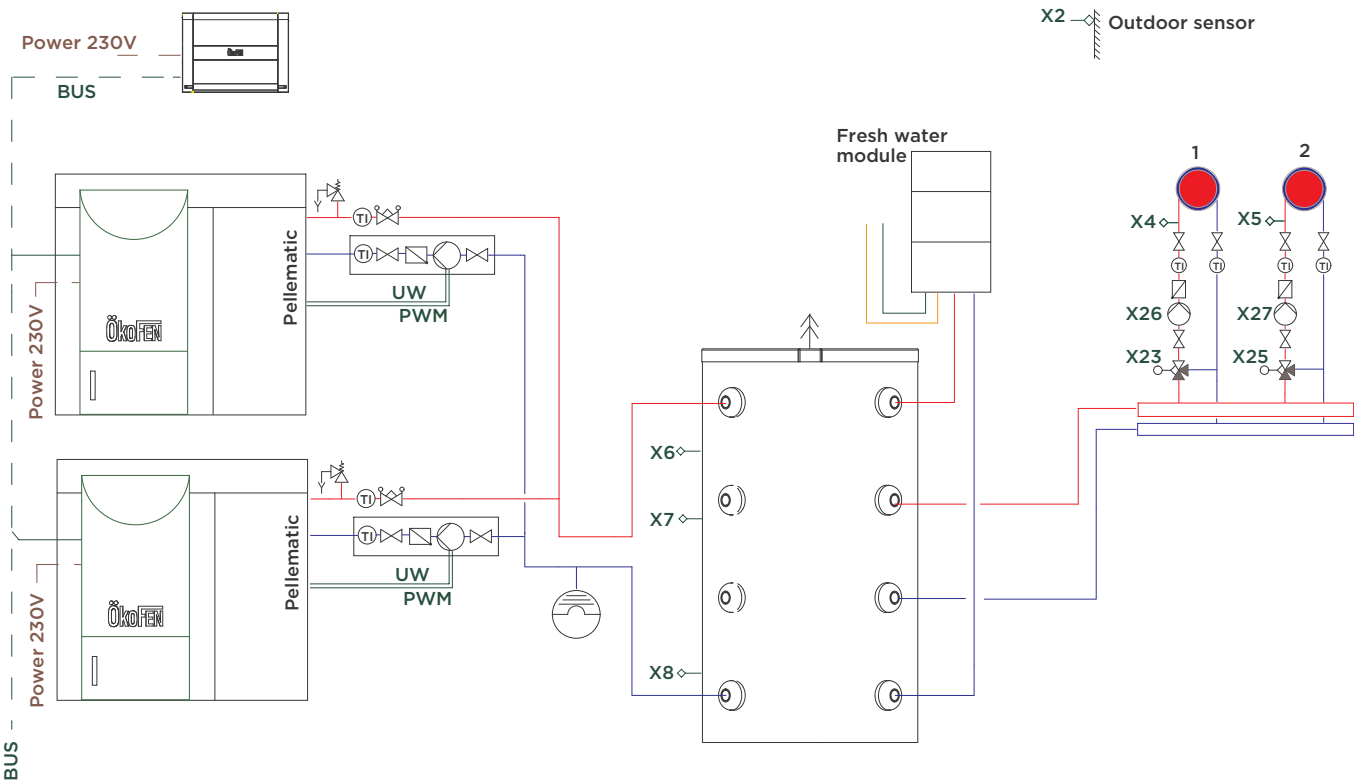

8.8.1.12 Diagram 12

4 Boilers Pellematic – 1 Accumulator Pellaqua – 2 Heating circuits

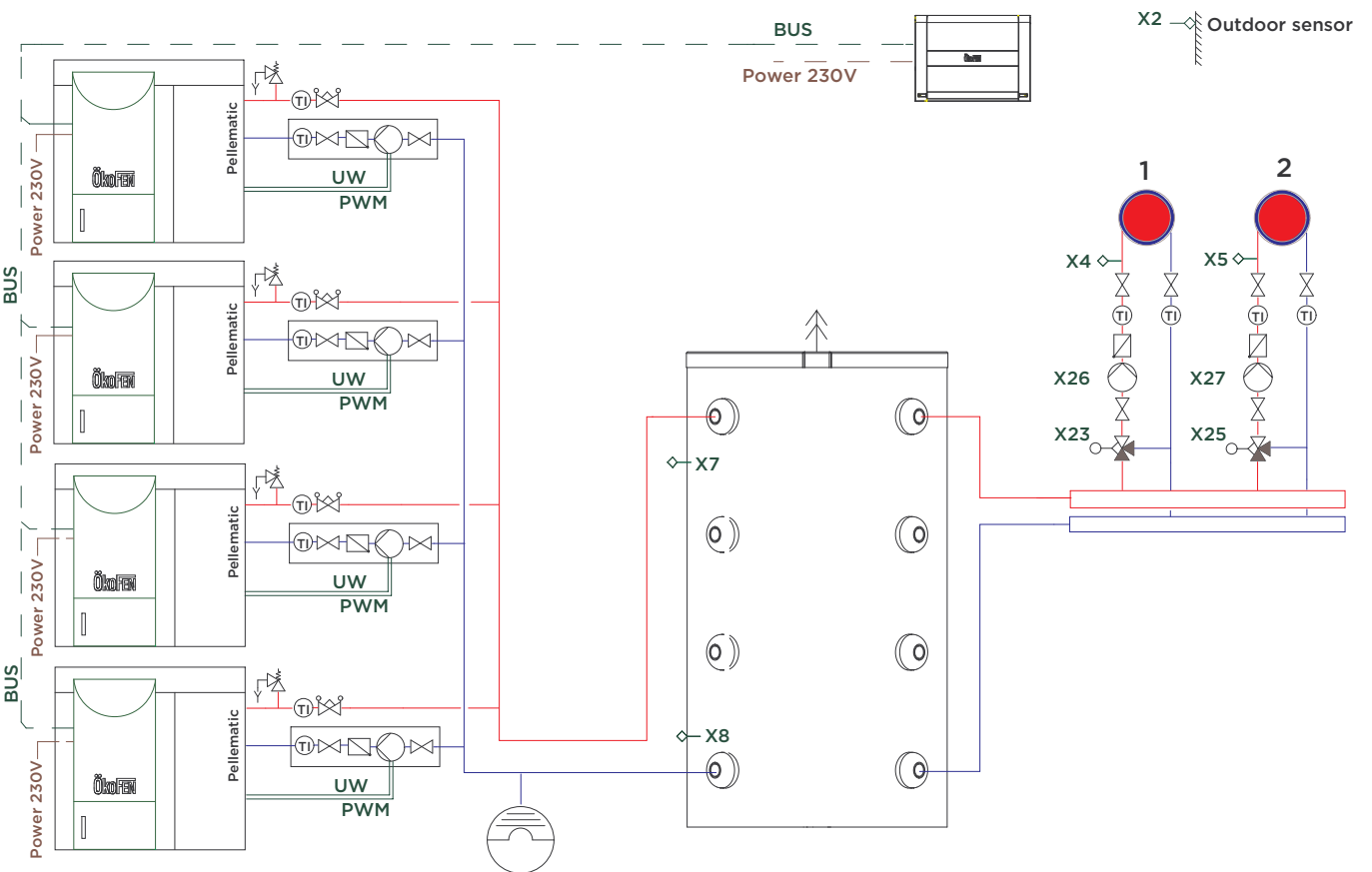

8.8.1.13 Diagram 13

1 Boiler Pellematic – 1 Wood boiler – 1 Accumulator Pellaqua – 1 DHW Accumulator – 2 Heating circuits – 1 Solar circuit

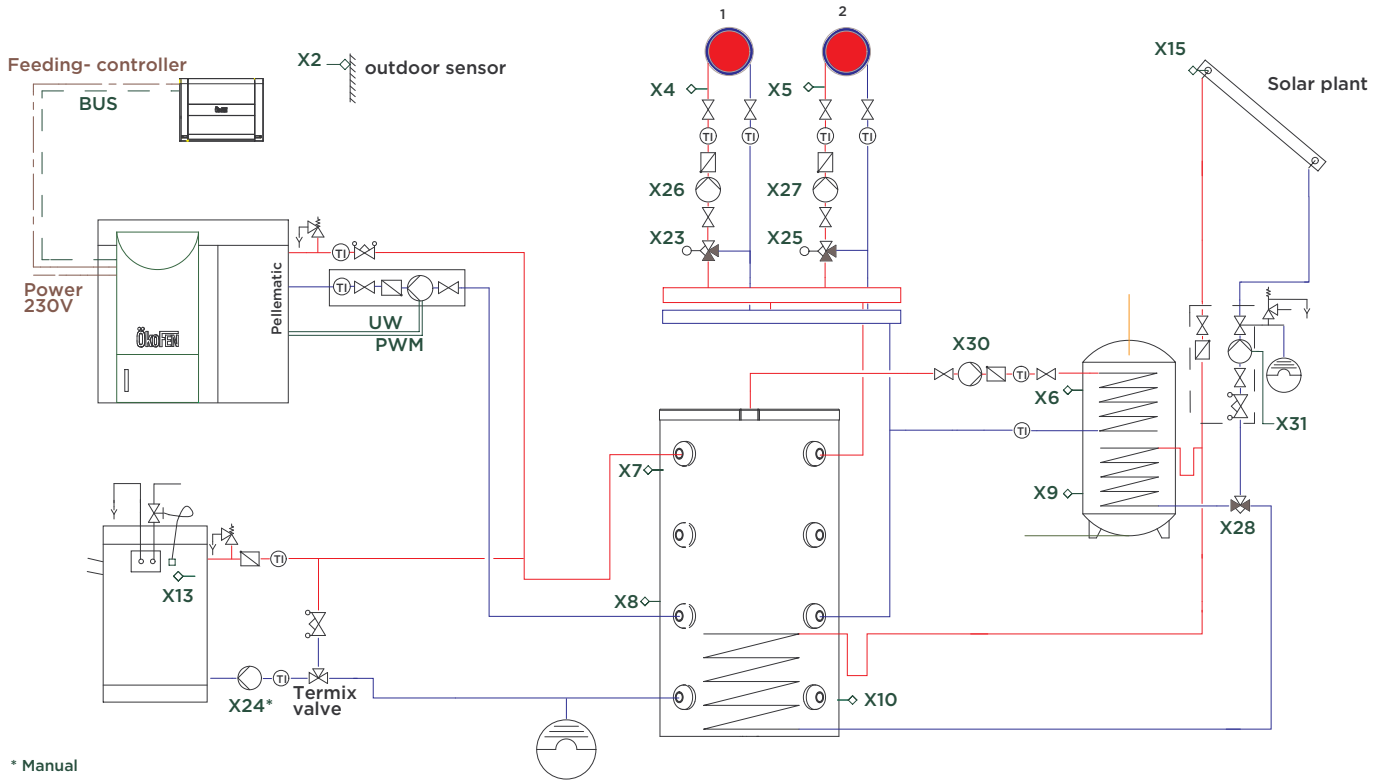

* Manual
 Note:
 X24 is a potential free contact to trigger an external heating boiler.

8.8.114 Diagram 14

1 Boiler Pellematic - 1 Wood boiler - 1 DHW Accumulator - 2 Heating circuits - 1 Solar circuit

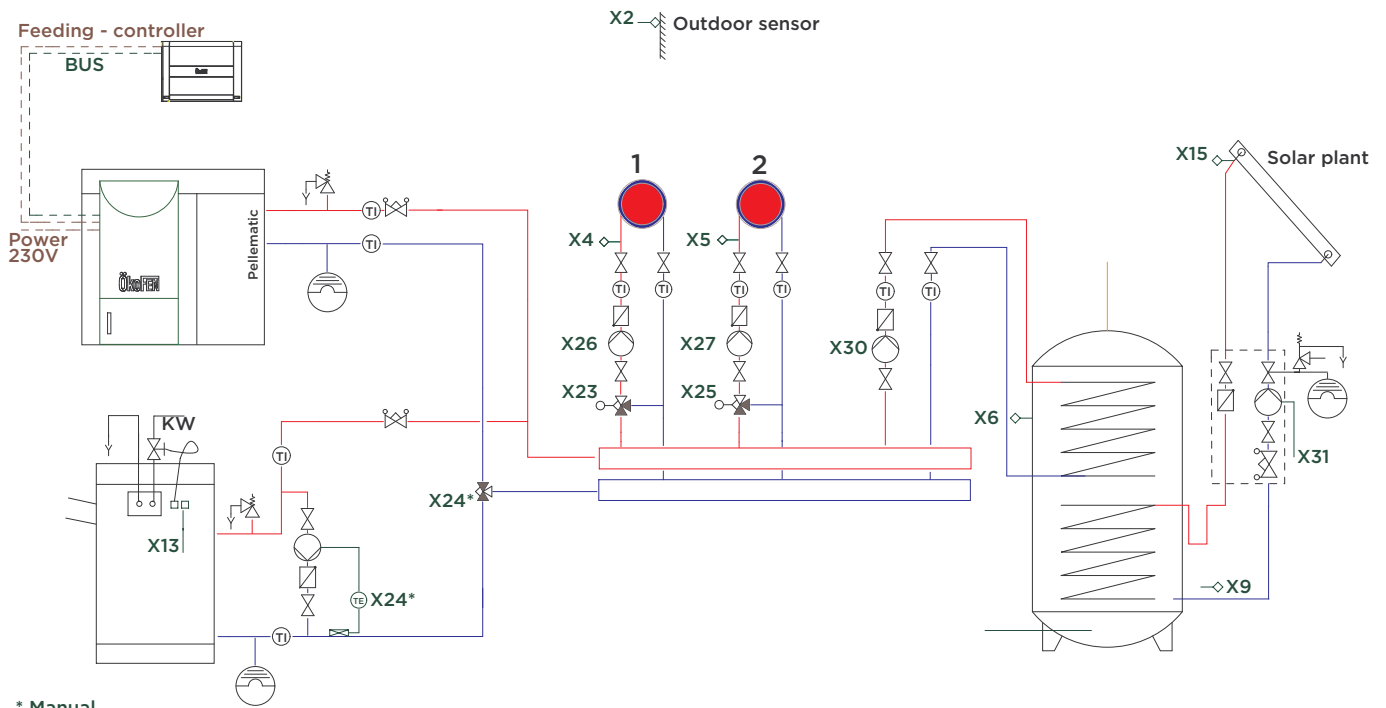

* Manual

Note:

If the value of the boiler sensor from the existing boiler (X13 S2) rises above the switch temperature, the Pellematic is switched off.

After reaching the adjusted pump enabling temperature, the diverter valve (X24) switches. Energy can be taken from the existing boiler.

X24 is a potential-free contact for regulating an external boiler.

8.8.1.15 Diagram 15

1 Boiler Pellematic – 1 Accumulator Pellaqua – Circulation on Accumulator Pellaqua – Yield Measuring Solar

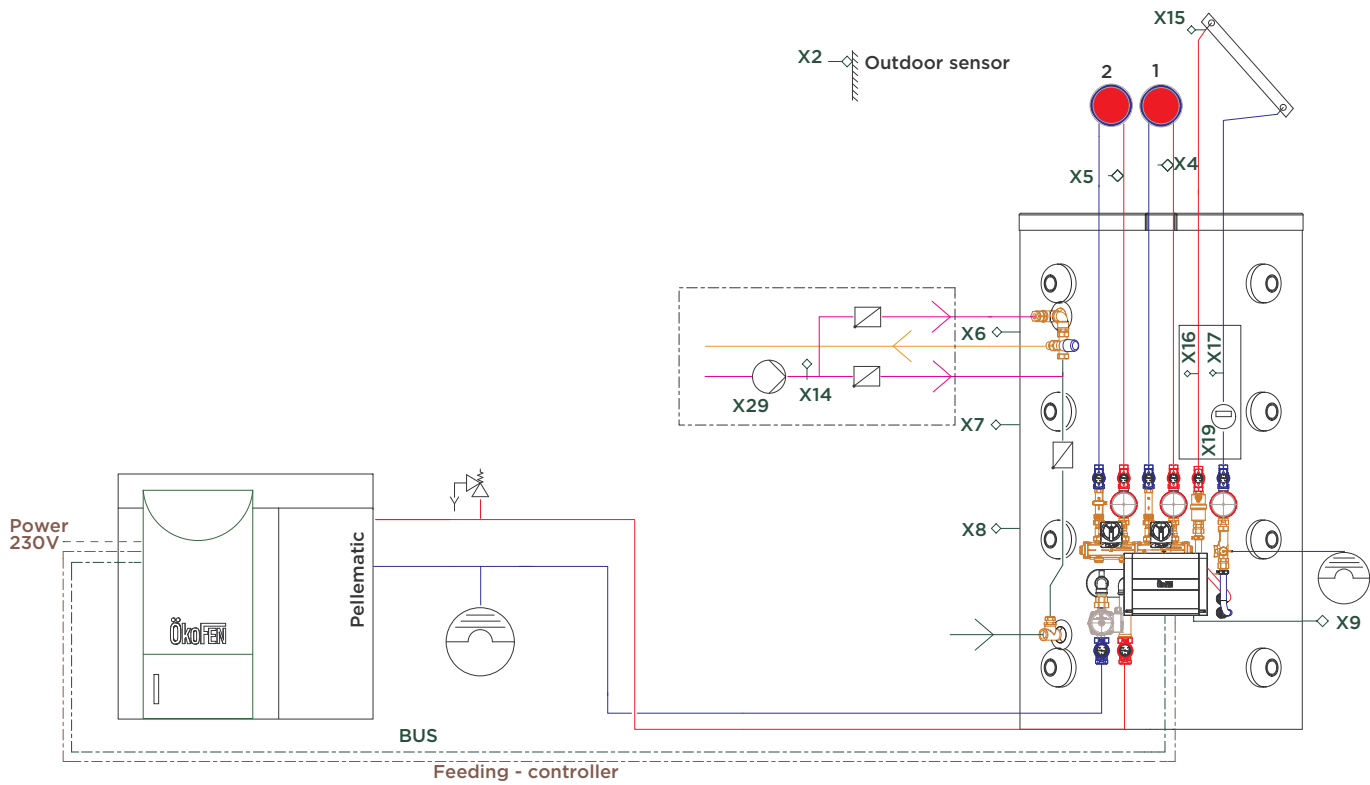

* Manual

Note:

If the value on the boiler sensor from the existing boiler (X13 S2) rise above the switch temperature the pellematic will be switched off. After reaching the adjusted pump on temperature, the diverter valve (X24), so that the energy can be taken from the existing boiler.

9 The Touch operating device

The Touch operating device is mounted on the control board of Pellematic. The 4.7" color display is surrounded by a foil design with logo. With finger pressure you make settings on the Touch operating device.

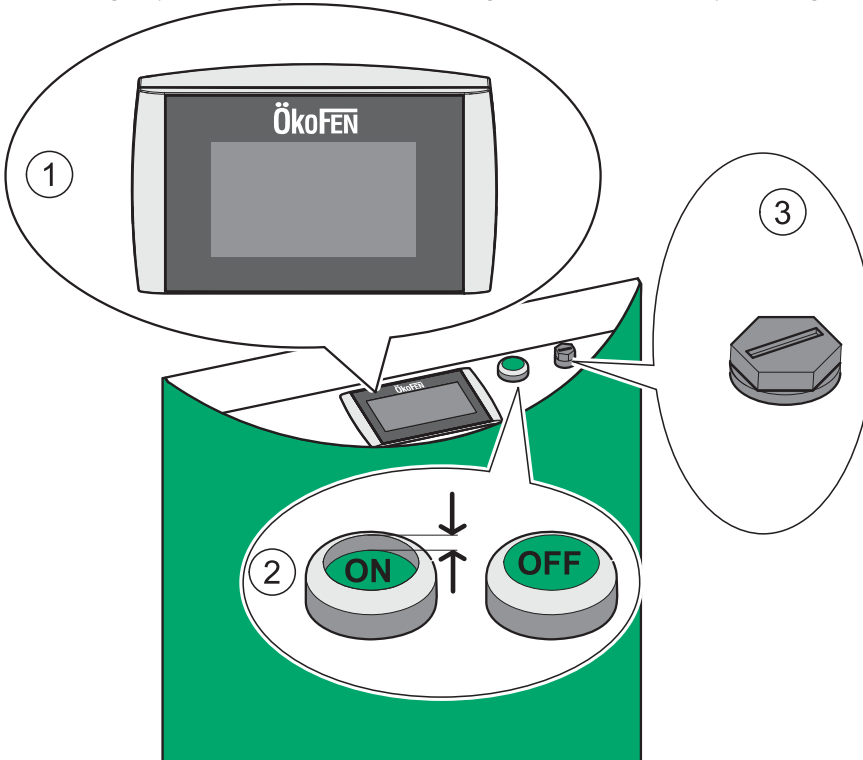

1	User control unit	Operates the boiler controller and the heating controller.
2	Main switch	Switches off the heating system (both poles) including the power supply to the control panel.
3	Safety temperature sensor	Switches the heating system off if the boiler temperature reaches 95°C. The heating controller remains active.

The touch panel is dark during in standby mode. As soon as you touch the surface of the touch, light turns on and displays the opening window.

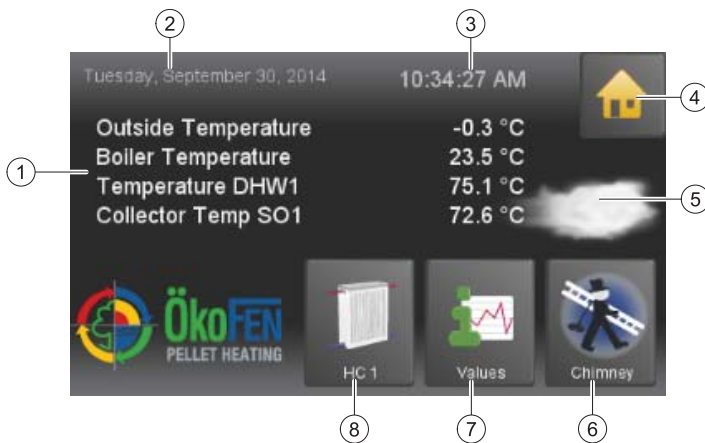

- 1 Measuring values (adjustable)
- 2 Date
- 3 Hour
- 4 The icon house takes to the main menu
- 5 Weather

Note:

If there is a malfunction, the corresponding fault message is displayed at this point instead of the weather icon

- 6 Favorite 1 (adjustable)
- 7 Favorite 2 (adjustable)
- 8 Favorite 3 (adjustable)



Favorit is in the menu General.



With this function you can display most commonly used menus in the start menu. This enables you a direct access. Select 1-3 menu items that should be displayed as a favorite in the Start menu.

9.1 User controls and their function

1. Navigation-icons

Icon-view

If you touch an icon, the icon turns green. The green shows that you are currently on this icon. You get to the enabled menu item .



The yellow house enters you directly to the main menu.



The horizontal arrow leads you one step back.



With the blue down arrow you get to additional lines of information on this item. (Down - scroll down).



With the blue up arrow you get to additional lines of information on this item. (Top of page - scroll up)



You get to the respective menu item.

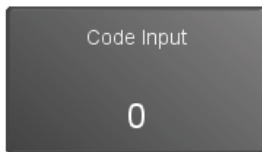

You get to the settings of the parameter. You come either to a numeric keypad, a time / date block or the text selection.

2. Numeric keyboard

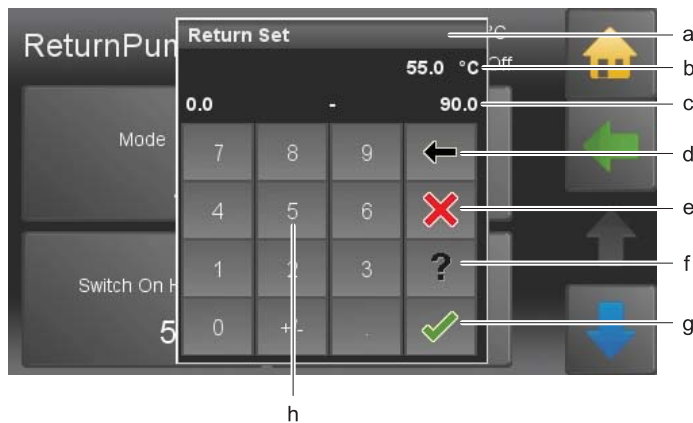

- a. Name of parameter
- b. Value of parameter with unit
- c. Min/max value - Values outside this range are not accepted.
- d. Delete input of numbers - per contact you delete one place.
- e. Cancel - You return to the menu item. Input of a new value was not accepted. The original value is.
- f. Help function - inactive
- g. Confirm
- h. Numeric keyboard - used to enter values within the min - max range.

3. Time and date block

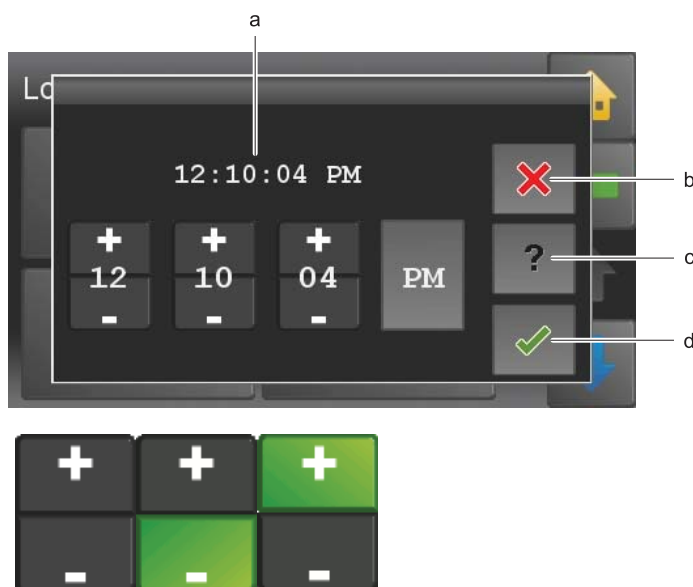

- a. Adjustable time or date
- b. Cancel
- c. Help function - inactive
- d. Confirm

With the Plus Minus block you change numbers.

4. Text selection



- a. Name of parameter
- b. Status texts
The number of status texts depends of the parameter.

Choose a status text. The setup menu closes automatically and the chosen status text is displayed in the menu.

Note:

Although a scroll down menu is open, the navigation icons, menu items and parameters behind are active and by touching them it takes you directly there .

9.2 Main Menu

In the Main menu you see all submenus. By finger pressure on an icon you reach the respective submenu.



NOTICE

A detailed description of the single meus is to be found in the Manual for End Users in the chapter Startup procedure.

9.3 Replacing a Touch operating device

Exchange the integrated operating device (in the control panel) as follows:



DANGER

Electric shock

Switch off the system when working on the boiler.

NOTICE

Breakdown Touch operating device

Before you press out the Touch operating device, you must unplug all cables from the operating device.

While pressing out the operating device you have to counter the top with the palm, so that the operating device does not pop out and falls to ground.

NOTICE

If the new operating device has a different software state, an update has to be done. All Bus-connected components have to have the same software-state.

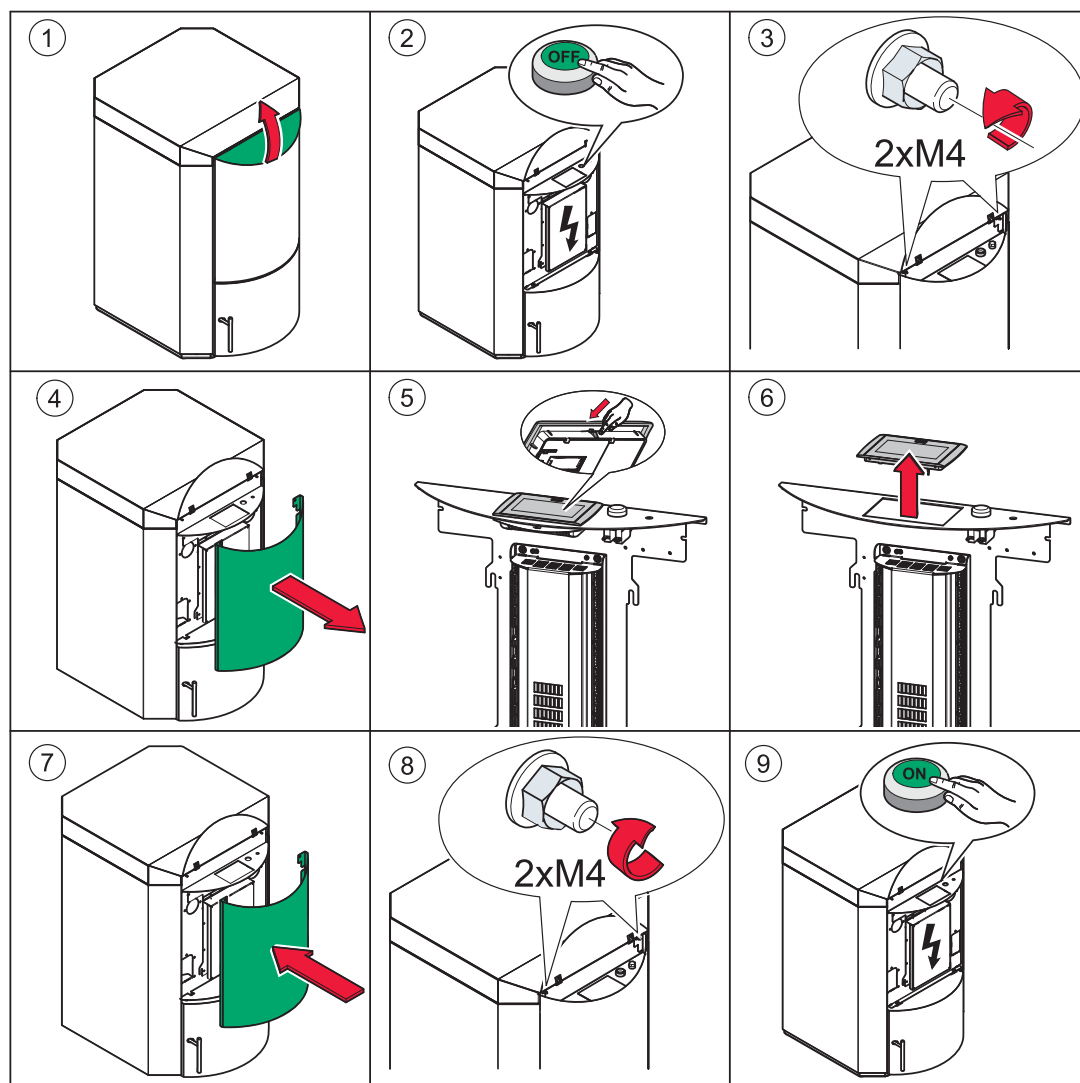

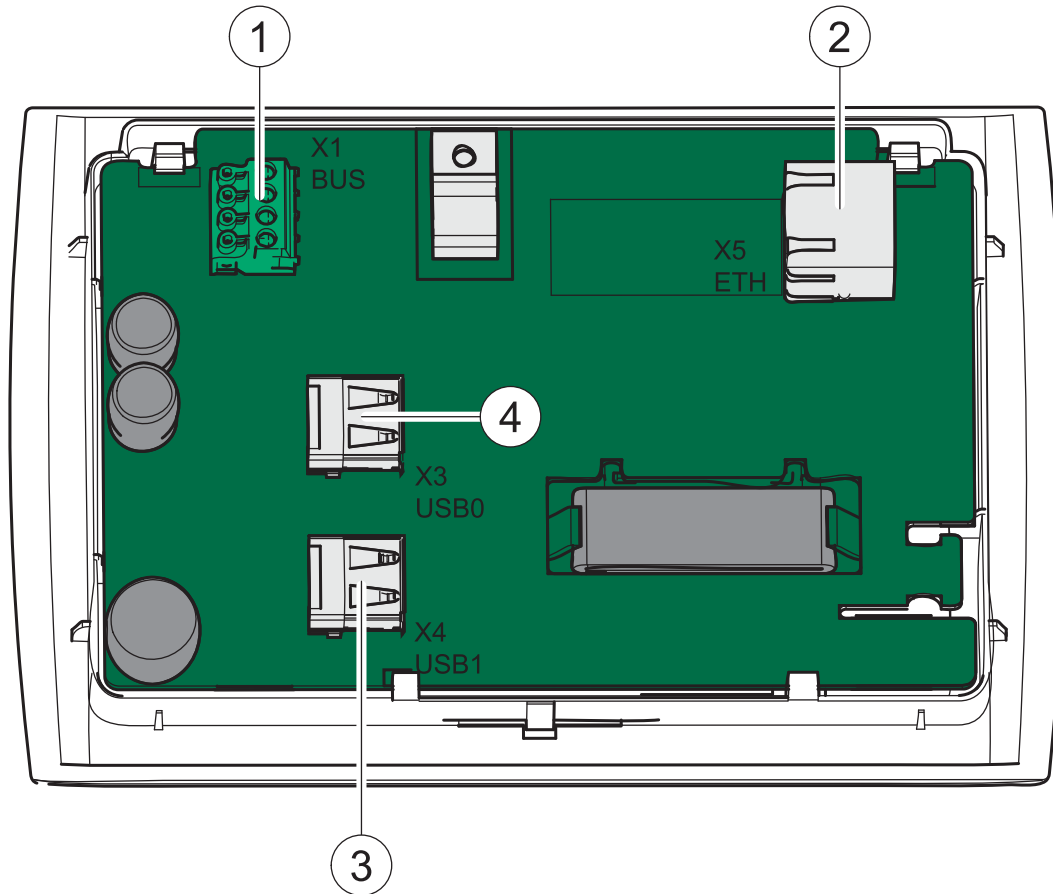

9.4 Backside of the Touch operating device



1	Bus connection <ul style="list-style-type: none"> • 1 ► +24V • GND ► GND • 2 ► A • 3 ► B
2	Ethernet port
3	USB-port USB1
4	USB-port USB0

9.5 Calibration

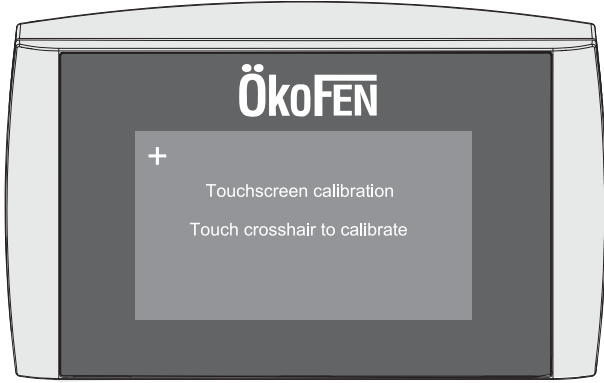
Execute a decalibration as follows:

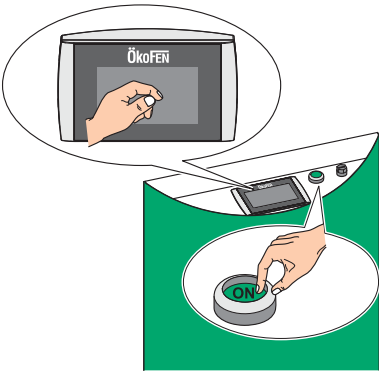
1. Switch off the whole heating system	4. After a few seconds of waiting time the following mask appears on the Touch operating device:
	
2. Press by using a finger on the Touch operating device.	5. Now press the crosshairs in the row they appearing concentric. Use a pen or similar for a more precise adjustment.
	
3. Keep your finger pressed and switch the boiler on again.	
	

NOTICE

Property damage

Watch for a careful way of dealing with the touch surface!

NOTICE

Decalibration

Avoid the placing of items on the touch operating device!

10 Default values and settings

Customer	Default	System			
		Boiler 1	Boiler 2	Boiler 3	Boiler 4
Operating mode					
Operating mode	Auto				
Ignition					
Burner Auger Run Time	70 zs				
Rest time	20 zs				
Fan	100 %				
Flue Gas Fan	100 %				
Temp Hysteresis Softstart	40 K				
Heating Full Power					
Brennstoffkorrektur	0				
Min Abgastemp.	50 °C				
Run on					
Speed Flue Gas Fan	100 %				
Flue Gas Fan Run On Time	1800 sec				
FRT + KT Flue gas fan Off	30 K				
Cleaning					
Mode	Ashbox				
Run time min	80 min				
Delivery Duration	3 min				
Boiler run on time	6 h				
Boiler cleaning					
Cleaning/Filling	20:00				
Cleaning 2	8:00				
Run time min	12 h				
Cleaning time	120 sec				
Negative Draft					
Mode	ON				
Malfunction time	60 sec				
Set Value ++	0 EH				
Minimum ++	0 EH				
Wash ++	0 EH				
PID Controller - Amplify	30 %				
PID Controller - Time Integral Action	130 sec				
PID Controller - Time Differential Action	20 zs				
FRT Control					

Mode	ON				
Temperature min	120 °C				
Set Value ++	0 K				
Limit above	30 %				
Limit below	80 %				
PID Controller - Amplify	4 %				
PID Controller - Time Integral Action	200 sec				
PID Controller - Time Differential Action	2 zs				
Pellet level					
Mode	Off				
Threshold level	400 kg				
Correction value	0 kg				
Boiler Controlled Pump					
On Temp	60 °C				
Depends on Require	On				
Pump type	Standard				
Switch Off Hyst	3 K				
Run On Time	15 min				
Control range	5 K				
Vacuum turbine					
Filling	19:00				
Tact RA Motor	55 sec				
Pause RA Motor	5 sec				
Suction intervall	180 min				
Magnetventil					
Mode	On				
Min runtime	5 h				
Washing time	60 sec				
Settings					
Control Temperature	70 °C				
Switch Off Temp	76 °C				
Malfunction mode	On / Off				
Hand filling hopper	Off				
Capacitive sensor RA -active	Off				
Capacitive sensor ZW -active	Off				
Switch on hyst	10 K				
Output SM	Standard				
Input AK	Standard				
Outputs					

Vacuum turbine - Threshold current Min	0 mA				
Vacuum turbine - Threshold current Max	15000 mA				
Vacuum turbine - Malfunction time min	20 sec				
Vacuum turbine - Malfunction time max	720 sec				
Ignition stick - Threshold current Min	0 mA				
Ignition stick - Threshold current Max	2500 mA				
Ignition stick - Malfunction time min	20 sec				
Ignition stick - Malfunction time max	20 sec				
Reserve 1 - Threshold current Min	0 mA				
Reserve 1 - Threshold current Max	2500 mA				
Reserve 1 - Malfunction time Min	20 sec				
Reserve 1 - Malfunction time Max	20 sec				
Magnet valve - Threshold current Min	0 mA				
Magnet valve - Threshold current Max	2500 mA				
Magnet valve - Malfunction time min	20 sec				
Magnet valve - Malfunction time max	20 sec				
Flue gas fan - Threshold current Min	0 mA				
Flue gas fan - Threshold current Max	2500 mA				
Flue gas fan - Malfunction time min	20 sec				
Flue gas fan - Malfunction time max	20 sec				
Boiler controlled pump - Threshold current Min	0 mA				
Boiler controlled pump - Threshold current Max	2500 mA				
Boiler controlled pump - Malfunction time min	20 sec				
Boiler controlled pump - Malfunction time max	20 sec				
Delivery system - Threshold current Min	0 mA				
Delivery system - Threshold current Max	2500 mA				
Delivery system - Malfunction time min	20 sec				

Delivery system - Malfunction time max	20 sec				
Delivery - Threshold current Min	0 mA				
Delivery - Threshold current Max	2500 mA				
Delivery - Malfunction time min	20 sec				
Delivery - Malfunction time max	20 sec				
Optimised stratification - Threshold current Min	0 mA				
Optimised stratification - Threshold current Max	2500 mA				
Optimised stratification - Malfunction time min	20 sec				
Optimised stratification - Malfunction time max	20 sec				

11 Default values and settings

Customer		System					
Master operating mode							
Master operating mode	Auto						
Heating circuit		HC 1	HC 2	HC 3	HC 4	HC 5	HC 6
Operating mode	Auto						
Set room temperature	22.0°C						
Set back temperature	18.0°C						
Time programme 1	active						
Time programme 2	inactive						
MO - SO	06:00 - 21:00						
	00:00 - 00:00						
	00:00 - 00:00						
Party function	inactive						
Party function till	act. Time						
Vacation time	OFF						
Temperature	15°C						
from	act. Date/Time						
till	act. Date/Time						
Heating curve/ Heating limits							
Heating curve	0.4						
Base point	20.0°C						
H limit heating	18.0°C						
H limit set temperature	minus 5°C						
Derivative time	180 min						
Room thermostat influence	1						
Room thermostat hysteresis	0.0°C						
Settings							
Maximum flow temperature	55.0°C						
Minimum flow temperature	20.0°C						
Temperature of boiler above heating circuits	5.0°C						
Type of heating circuit	mixed						

Mixer opening	5 sec						
Mixer off	15 sec						
Mixer closing	5 sec						
Boiler load range	10.0°C						
Flow range	10.0°C						
BT smoothing							
Temperature increase	2,5°C						
Control range	6.0°C						
Screed programme							
No. of heating days	21						
Flow set	every day 20° C						
Screed programme	inactive						
Domestic hot water		DHW 1	DHW 2	DHW 3			
Operating mode	Auto						
DHW boost	OFF						
Actual water temperature	60.0°C						
Water temperature minimum	30.0°C						
Time programme 1	active						
Time programme 2	inactive						
MO - SU	06:00 - 21:00						
	00:00 - 00:00						
	00:00 - 00:00						
Settings							
DHW preference	ON						
Temperature of boiler above heating circuits	10.0°C						
Run on time	10 min						
DHC hysteresis	5.0°C						
Legionella protection	Monday						
Accumulator		AC 1	AC 2	AC 3			
Settings							
Accumulator Temp min ON	10.0°C						
Pump release temperature	20.0°C						
Pump Depends on Require	ON						

Pump Speed Controller	OFF						
Pump Switch Off Hyst	3K						
Pump Run On Time	15min						
Pump Control Range	5K						
Solar		SO 1	SO 2	SO 3	SO 4	SO 5	SO 6
Operating mode	Auto						
Sol pump switch on	10.0°C						
Sol pump switch off	5.0°C						
TPU max	60.0 °C						
TPU hyst	5.0°C						
Collector smoothing	OFF						
Collector Temp Min	60.0°C						
Control range	10.0°C						
Settings							
Limit Sensor	AC lower sensor						
Collector Temp Max	130.0°C						
Hysteresis for maximum collector temperature	30.0°C						
Type of pump	Standard						
Speed controller	OFF						
Collector protection	OFF						
Protection temperature	120.0°C						
Protection hysteresis	10.0°C						
Scavenging	OFF						
Rest time SV	10 min						
Run time SV	1 min						
Coll min SV	20.0°C						
Period Scavenging	09:00 - 18:00						
Priority	x						
Run time	x						
Rest time	x						
Scavenging time	x						
Solar energy							
Volume per pulse	1.0 l						
Heat main pump							
Operating mode	Auto						
Member	NO						

System Controlling							
Settings							
Boiler Temp Above	10.0°C						
Boiler temperature minimum	60.0°C						
System Max	95.0°C						
Boiler Pump On Temp	60°C						
Outside Temperature - Time of Average	4.0°C						
Frost protection Scavenging time	5 min						
Frost protection Pause Time	60 min						
General							
Language	Deutsch (German)						
USB							
Recording	OFF						
Recording interval	1 min						
Sensor calibration							
Sensor	all sensors 0.0° C						
Existing boiler							
Valve switch on temperature	60.0°C						
Valve hysteresis	2.0°C						
Inversion UV	NO						
Delay time	30 min						
Pump switch on temperature	60.0°C						

12 Online Touch

12.1 Product Description

Pelletronic Online Touch facilitates remote maintenance at any time and from anywhere via the Internet. You monitor and operate the pellet heating system by PC via the remote maintenance website. You can check and set the parameters for the heating controller and the pellet boiler via this password-protected remote maintenance website. Furthermore, you can receive messages by e-mail, display system data and archive this data.



12.1.1 Installation Requirements

The following **requirements** must be met before you can operate your pellet heating system with **Pelletronic Online**:

1. Permanent connection to the Internet via Router (DSL, UMTS, LWL, cable)
2. Fixed Internet IP address or dynamic Internet IP address.
3. Administration access to the router to configure port forwarding.
4. Network connection with network cable (or wireless bridge with a network cable), WLAN-stick or DLAN between the master control panel and router.
5. On the Internet router, the port 587 for sending E-Mails must be enabled.
6. Fixed Internet IP address (Local Area Network)
7. DNS (Domain Name Service)
8. A field D1 (DNS Server 1) optional D2 (DNS Server 2) has to be set at the IP-Adresses (see adjustments touch operating device).

NOTICE

Changes to the network and routers may be performed only by trained personnel.

12.1.2 System Description

The remote control web site is powered by the Internet-connected touch panel! You can connect the operating device via network cable or wireless stick (Recommendation ÖkoFEN: **Allnet ALL0234NANOv2**) to the internet! Assign the server an IP, NM (netmask) and GW (gateway), see **Settings on the Operating Device**. In the router settings (router via which you access the Internet - not included in the scope of supply) the port must be forwarded to the IP address of the web server (any port, it has to be the same port from the operating device)!

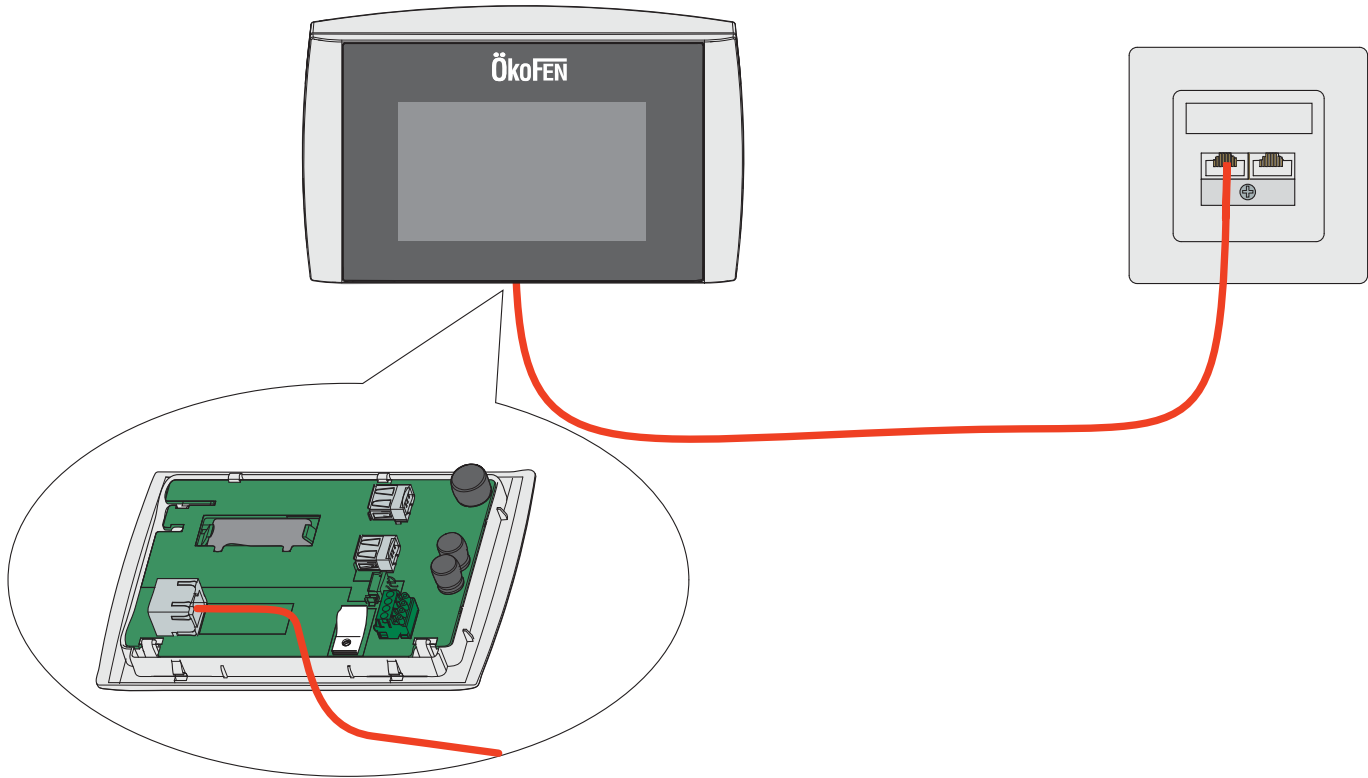

12.2 Settings on the Touch Operating Device



Please choose the submenu item **IP Config** in the menu General.

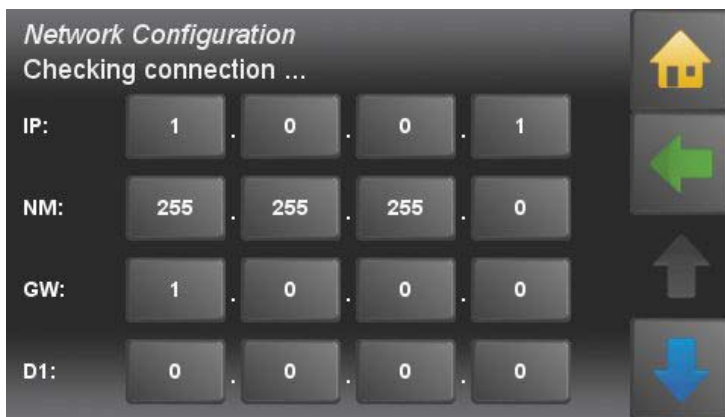

Insert the **IP (Adress)**, **NM (Netmask)** and **GW (Gateway)**, D1 (in most cases similar to GW) and **D2 (optional)**.

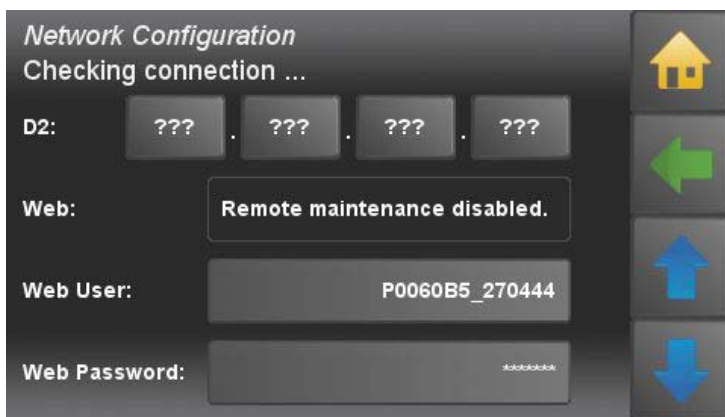

Web: Status or external address.

You need **Web User** and **Web Password** to log into the remote maintenance site.

Set depending of your network **DHCP** to **On** or **Off**.

Enter the **Port**. (standard **80**)



Activate the **Ping** function optional.

NOTICE

To prevent modem from switching to standby mode, every 10 minutes a ping command is executed.

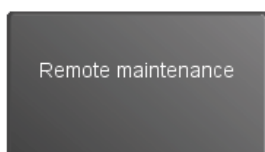

Automatic: This will attempt to automatically set up the router using the UPNP protocol port forwarding. If this service is disabled on the router or doesn't work properly, it is canceled accompanied by an appropriate error message. As this function is time-consuming (may take a few minutes), it is running in the background. Whatever the UPNP If available, the Touch operating device registers on the ÖkoFEN remote control server with it's current external IP Address. In case of change of address by the external provider, this is detected and sent to the server Ökofen.

Manual: In this mode, the port forwarding must be set manually. (for lack of UPNP) The port of the touch panel must correspond to the external shared port. The touch then registers with the external IP address and port on ÖkoFEN remote maintenance server. In case of change of address by the external provider, this is detected and sent to the ÖkoFEN server.

Static: In this mode, no connection data is transferred to the ÖkoFEN server and the online service of ÖkoFEN can not be used. But the remote controll of the Touch operating device remains active and can be uses as before via port forwarding, DynDns, fixed external IP, LAN and so on.



This function determines the network settings automatically. For this the DHCP mode is activated and the required settings are set automatically. Afterwards DHCP is deactivated. Because of this, the IP address of the contol unit can change.

Settings are set as follows:

- DHCP off
- Ping on
- Port 8080
- Remote maintenance: Automatic

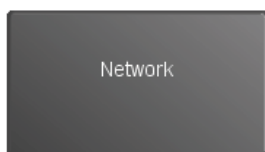

All functions who need the network/internet can be disabled here.

These data you get from your network technician.

12.3 Opening the Password-Protected Remote Maintenance Website

The remote maintenance website is accessed by entering the network address as follows:

1. Open the web browser, e.g. Internet Explorer.
2. Enter the address of the Internet connection: `http://_____` and press Enter. Your network technician will tell you the address of the Internet connection.

Procedure to follow in the event of error messages:

The page cannot be displayed

The page you are looking for is currently unavailable. The Web site might be experiencing technical difficulties, or you may need to adjust your browser settings.

Please try the following:

- Click the  Refresh button, or try again later.
 - If you typed the page address in the Address bar, make sure that it is spelled correctly.
 - To check your connection settings, click the **Tools** menu, and then click **Internet Options**. On the **Connections** tab, click **Settings**. The settings should match those provided by your local area network (LAN) administrator or Internet service provider (ISP).
3.
 - Check the Internet connection.
 - Check whether the web server is switched on.



The login window appears on the screen. Enter your **User name** and **Password**, see [12.2 Settings on the Touch Operating Device, page 59](#)

- Select the desired **Language**.
- Click on **Login**.

You are now logged in to the remote maintenance website.

Procedure to follow in the event of error messages:

You cannot log in to the remote maintenance website.

- Re-enter your **User name** and **Password** in the login window. Click on **Login**.
- Check your user name and password – see [12.2 Settings on the Touch Operating Device, page 59](#) Enter them in the login window again.
- Call your network technician.

12.4 Description of the Pelletronic Online Website

Start page of your code-protected ÖkoFEN website

The screenshot shows the ÖkoFEN online website interface. At the top left is the ÖkoFEN logo. At the top right is a green 'Logout' button (1). Below the logo, the date and time '12/15/2014 15:13' are displayed (2). The main content area is divided into two sections. On the left is the 'MAIN MENU' (5) with a grid of icons for 'Op. Mode', 'Weather', 'Eco Mode', 'HC 1', 'HC 2', 'DHW 1', 'CP1', 'Return P1', 'Solar 1', 'Pellematic 1', 'General', 'Software', and 'Code'. On the right is the 'NOTIFICATIONS' (3) section showing a 'PE 1 ash warning [5053]'. Below that is the 'VALUES' (4) section, which contains a table of system parameters:

	Act	Set
Outside Temperature	-0.2 °C	
Outside Temperature	21.6 °C	
PE 1 Boiler Mode	Off	
PE 1 Boiler Temp	21.7 °C	8 °C
Existing Boiler	66.5 °C	
Burner Contact	Off	
Switching Valve	On	
ACC1 TPO	53.5 °C	33.8 °C
ACC1 TPM	26.2 °C	33.8 °C
ACC1 Pump	0 %	

At the bottom right, there is a weather forecast for 'Niederkappel, Austria' showing 'leichter Regen 4 to 8 °C' (6) with a weather icon.

- 1 **Logout** Exit your ÖkoFEN website
- 2 **05/28/2015 09:42** Display of date and time
- 3 **Notifications** Indication of a malfunction of the heating system.
- 4 **Values** Display of all **current measuring values** and current desired values.
- 5 **Main Menu** Display of all **Pelletronic menu items** available in your system. **System configuration** is used to set up the website.
- 6 **Weather** Display current weather (only when weather function is active).

12.4.1 Making Settings

Description of how you make settings on the remote maintenance website.

Click and select the right submenu to make the required changes.



Now enter the desired value in the input field and click OK.



For each variable value, there is a bounded range of values. If your entered value lies outside the value range, Pelletronic Online Touch will not accept the value. The limited value range prevents the input of implausible settings.

Have you changed and confirmed a value, a message appears top right of the window: **successful saved value**

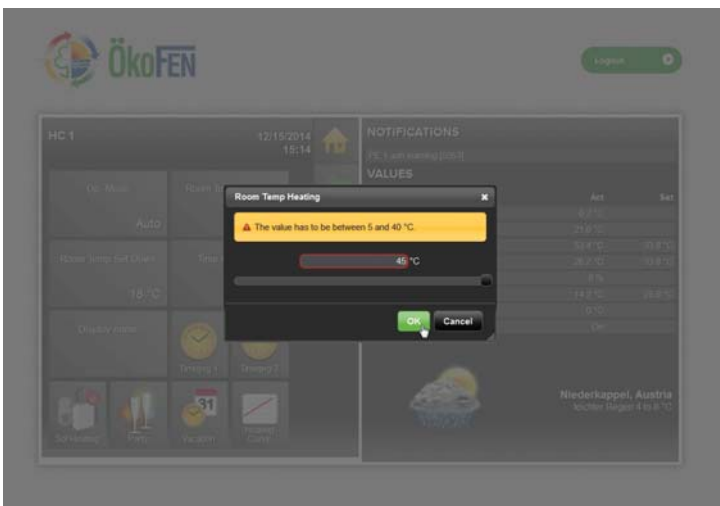

NOTICE

No real-time connection

The PL line guarantees because of the delay through the Internet no real-time connection.

12.4.2 Adjustment of the power rating

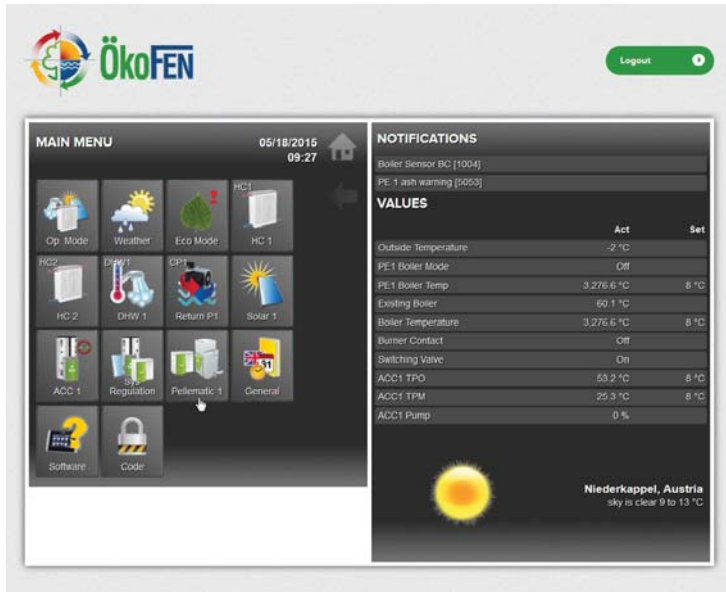

Settings is in the menu Pellematic.



Choose Settings per click.

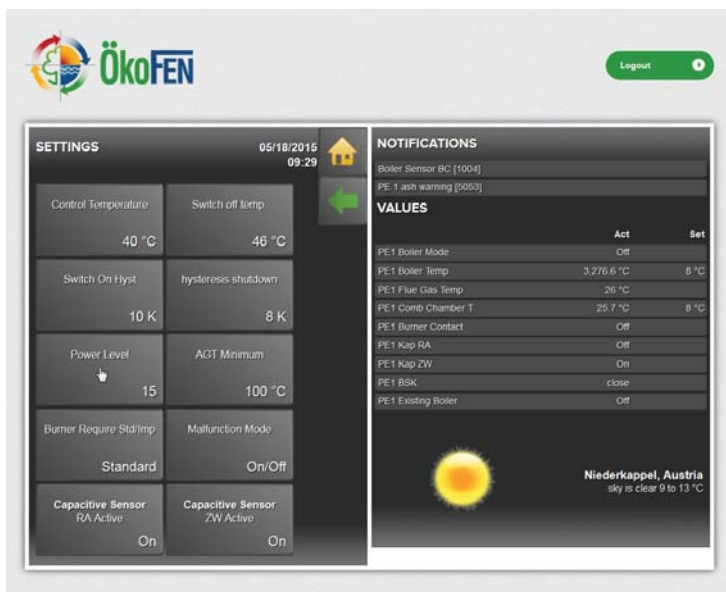

Note:

The adjustment of the boiler performance is only possible within the learned boiler size.

Note:

The adjustments of the Power level is only possible after inserting the code.

12.4.3 Error Messages by E-mail

If you select menu item **Internet** in menu **General**, you will get error messages by email.

General is in the main menu.

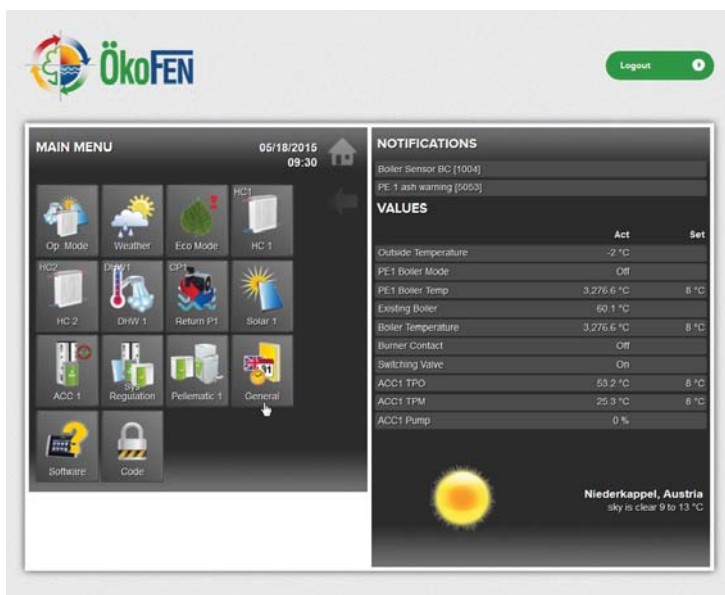

Choose **Internet** per click.



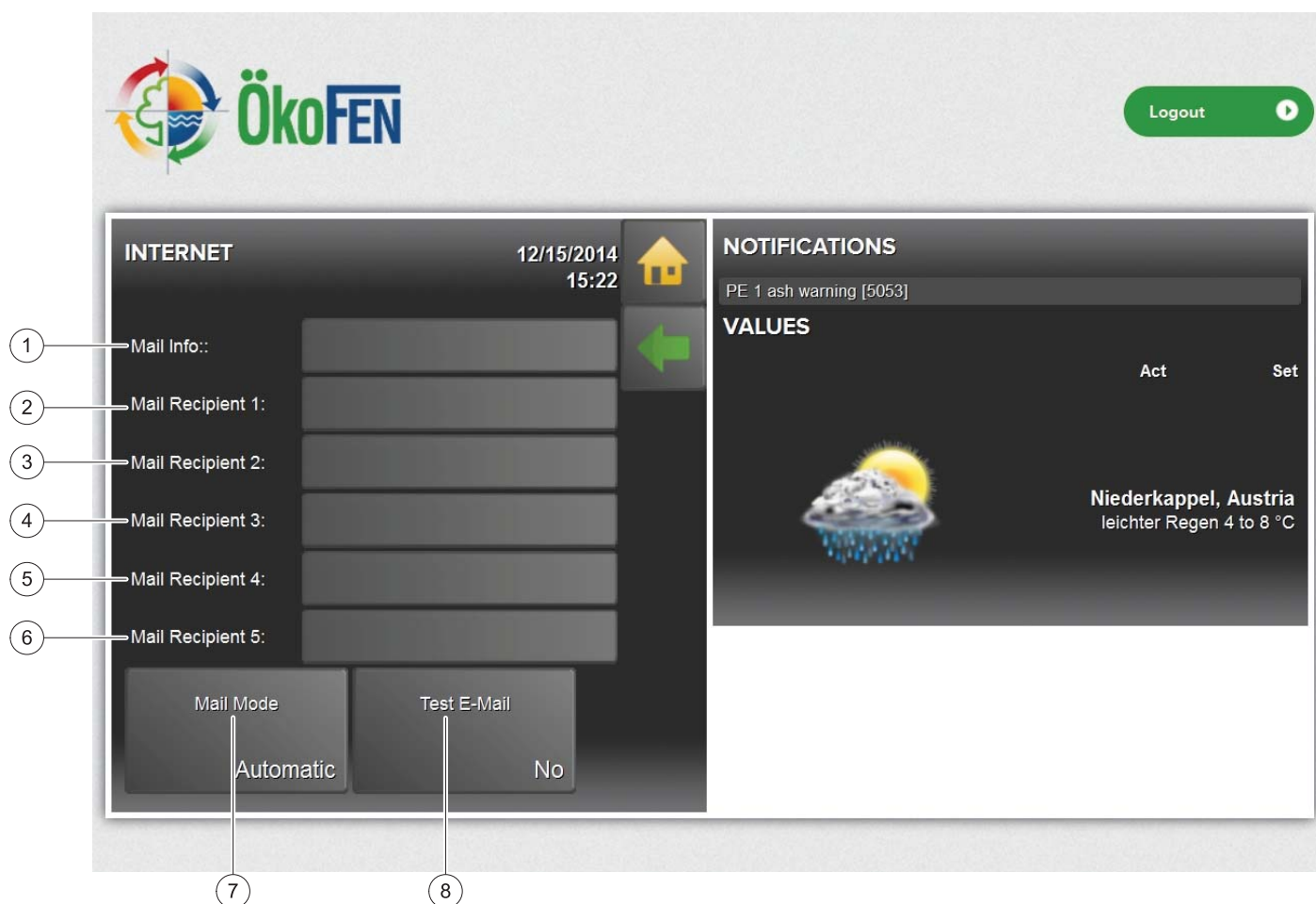

- 1 **Mail Info** Enter the name of the system (optional). Max 200 characters. The **Mail Info** is then in the email **subject heading** and the **text**. The subject is visible while forwarding a mail as text messages on the mobile phone.
- 2 **Mail Recipient 1** Enter mail address of the recipient 1.
- 3 **Mail Recipient 2** Enter mail address of the recipient 2.
- 4 **Mail Recipient 3** Enter mail address of the recipient 3.
- 5 **Mail Recipient 4** Enter mail address of the recipient 4.
- 6 **Mail Recipient 5** Enter mail address of the recipient 5.
- 7 **Mail Mode**

Automatic: The dispatch of error emails occurs via a ÖkoFEN server. You just have to enter the recipient's address.

Manual: To provide maximum flexibility, you can carry out the email settings by yourself.
- 8 **Test E-Mail** Send a test e-mail to the **mail recipient** to verify the **connection**.

12.4.4 Quit malfunction

Quit malfunction is in the menu **Pellematic**



Click to select **Quit malfunction**



Click On and confirm with **OK**.



12.4.5 Code input

The code input extends the **menu items** and **settings for the service technician**.



Choose **Code** by clicking on the button.



Then choose **Code input**.



Type in the code in the appropriate field.

13 Starting up for the first time

After bringing in the boiler, connecting up the hydraulics and power supply, the unit can be started up for the first time.

The unit must be started up for the first time by an authorised ÖkoFEN service technician.

- Before the initial start up, the correct electrical wiring of the boiler controller, the heating controller and all other components must be checked.
- Check the system pressure and make sure, that the system is completely deaerated.

NOTICE

Density of the combustion chamber

To ensure a trouble-free operation, the density of the combustion chamber must be given.

NOTICE

Material Damage

The valid operating temperature of the boiler controller is between 5°C and 50°C

13.1 Performance adjustment

The heat exchanger of an ÖkoFEN pellet boiler is changeable in every assembly. That can be made by opening or closing of the heat exchanger pipes. So the power rating is adjustable. If the delivery condition varies from the enclosed data plate, the service technician has to adjust the power rating before the initial start up.

13.2 Setting the addresses of the Bus-participants

Before the boiler controller gets connected to the power supply, they have to be addressed.

NOTICE

Material Damage

Adjustments with the adress switch are only possible if the whole system is powerless.

13.2.1 Setting the address at the burner controller

The burner controller has an address switch. If operating a cascade system this address switch must be set accordantly.

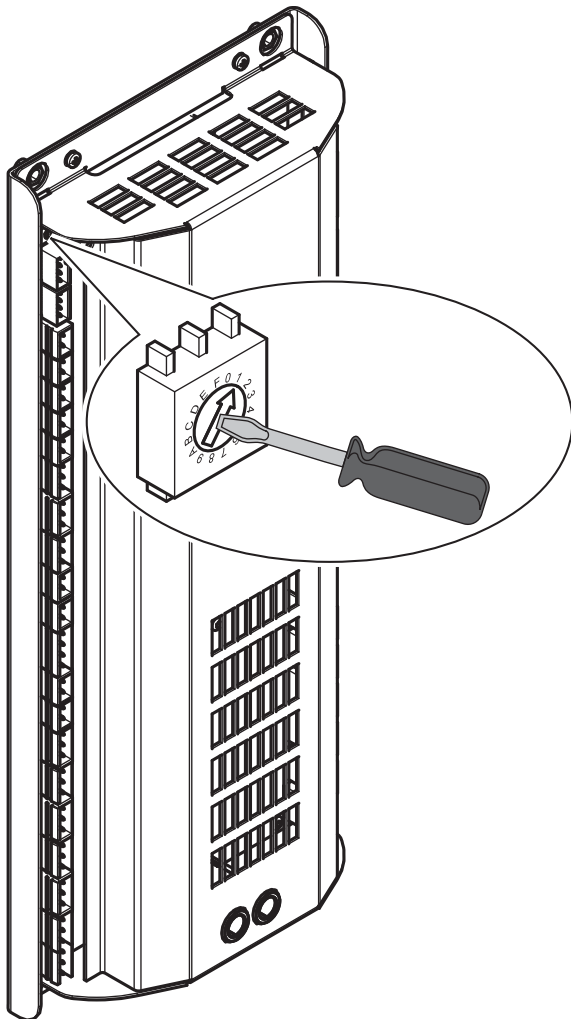

Note:

The screwdriver for adjustment of the adress adder is enclosed to delivery of the boiler controller..

Base setting= 0	Switch position = 0
System with 1 boiler	Switch position at boiler control = 0 (adjustment ex works)
System with 2 boiler	Switch position at boiler control boiler 1 = 0 Switch position at boiler control boiler 2 = 1
System with 3 boiler	Switch position at boiler control boiler 1 = 0 Switch position at boiler control boiler 2 = 1 Switch position at boiler control boiler 3 = 2
System with 4 boiler	Switch position at boiler control boiler 1 = 0 Switch position at boiler control boiler 2 = 1 Switch position at boiler control boiler 3 = 2 Switch position at boiler control boiler 4 = 3

13.2.2 Setting the address at the heating controller

The adress switch is inside the wall box of the heating controller.

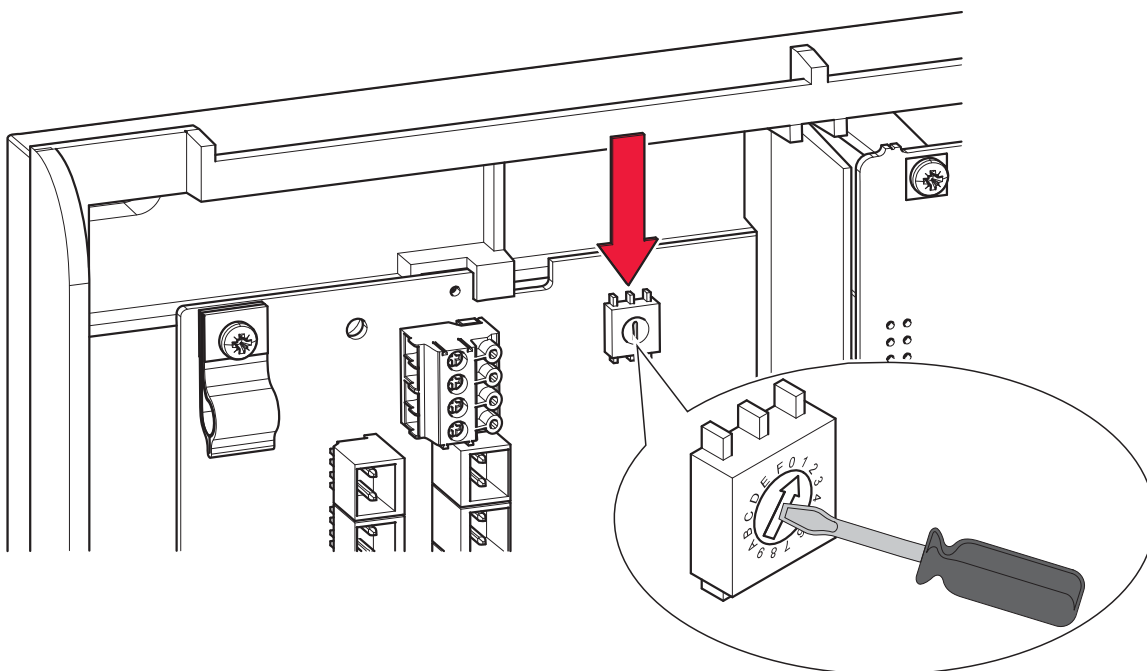

Note:

The screwdriver for adjustment of the adress adder is enclosed to delivery of the heating controller.

At every wall box (heating controller) max. 2 heating circuits, 1 solar system (2 solar circuits), 1 DHC und 1 buffer can be connected. Alltogether max. 3 wall boxes (= 6 heating circuits, 6 solar circuits, 3 DHC and 3 buffers) are possible.

The adress adder allocates the heating circuits and DHC systems or buffers to a wall box.

Base setting	Switch position= 0
Wall box A	Switch position 0 = heating circuit1 + 2, Solar circuit1 + 2, DHW 1, Accumulator 1
Wall box B	Switch position 1 = heating circuit 3 + 4, Solar circuit 3 +4, DHW 2, Accumulator 2
Wall box C	Switch position 2 = heating circuit 5 + 6, Solar circuit 4 + 6, DHW 3, Accumulator 3

13.2.3 Setting the address for the remote control

The addressing of the bus participants remote control touch (E1331) and remote control (E1396) starts after the Controll gets connected to power supply and the automatic system check is finished.

Note:

This will be described in the following chapters.

13.2.4 Settings before starting up

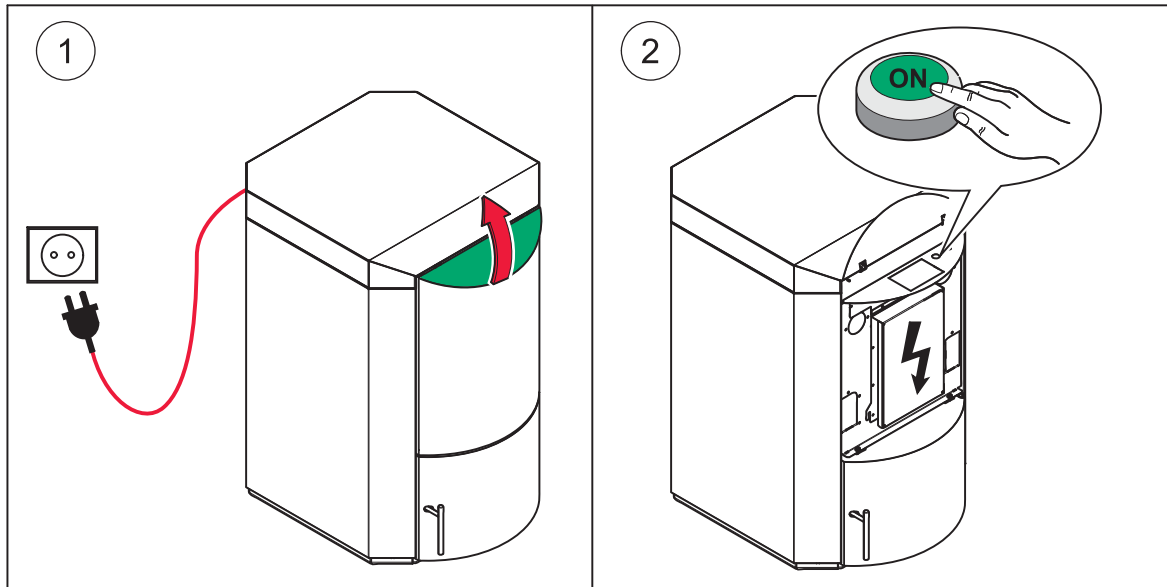

After connecting to the power supply and starting by pressing the main switch, the controller runs an automatic **system check**.

This process may take some minutes.

- Meanwhile the system is checked, the display shows the ÖkoFEN logo and a clock symbol.



- After the system check the display shows the start - main menu.

- For now the following buttons are displayed:



Only after finishing periphery learning the additional main menu buttons for every existing installed component e.g. HC 1, DHW 1, etc. will be shown.

13.2.5 Setting the adress for remote control Touch

In case a remote control Touch (E1331) was installed, it has to be addressed.



The description of the configuration is in the chapter **Touch configuration**.

13.2.6 Setting the adress for remote control

In case a remote control(E1396) was installed, it has to be addressed.



How to configurate the remote controll

allocation of heating circuits:

- Hold both arrows ▲ ▼ at the same time for ca. 4 seconds until LED  blinks yellow.
- Now adjust the heat circuit number with the - and + buttons.
- The amount of green LEDs on the left top corner is equal to the adjusted heating circuit number.
e.g.: If 3 LEDs are lightning, heating circuit number 3 is allocated.
- Hold both arrows ▲ ▼ again for about 4 minutes after the desired adjustment was made.
- In case of yellow light of the LED, the heating circuit number is taken over.
Afterwards the LED light changes to green.
Wait until the green blinking ends, then adjust all remote controls to the equevalent heating circuits.

Periphery learning

After adjusting all remote controls to their heating circuits, you have to run **periphery learning** on the operating device. After Periphery learning the heating circuit recognizes all to the system connected devices and sensores. If a heating circuit is connected to a remote control is to be seen in the menu item measuring values at **room temp**. If no remote control is conected to the sensor, an empty field is displayed.

13.2.7 Code Input

The heating controller is composed of a customer level and a level for the service technician. At the customer level, the operator can adjust the heating system to his needs. At the level of service technicians, advanced settings for startup and customization of the heating system are possible. The level for the service technician is protected with a password/code against unauthorized changes. After entering the password/code, more menu items appear in the menu structure.



Code Input is in the Main menu.

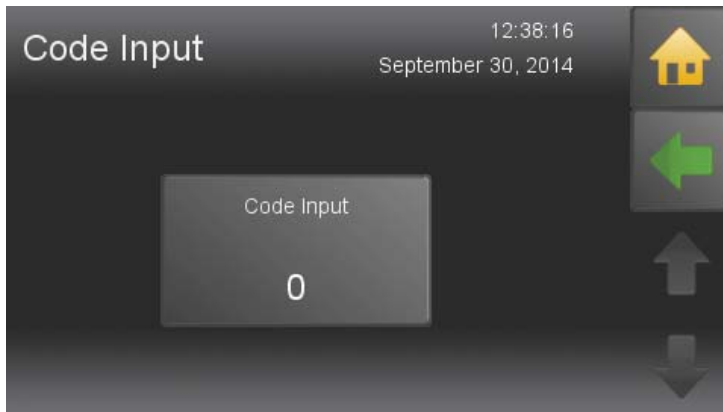

Touch the icon Code input.



Enter the code in the numeric block.

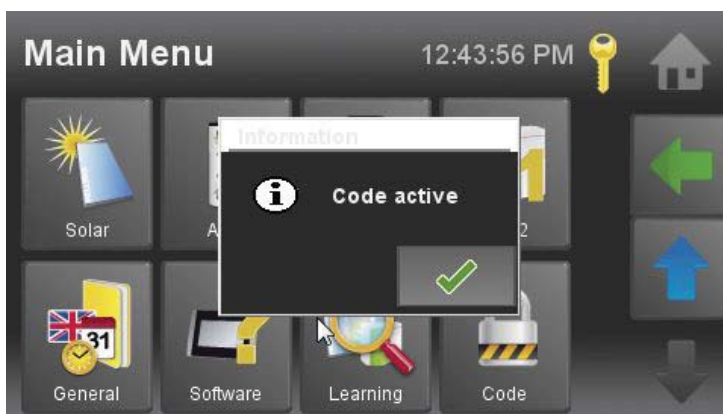

You have reached the level of service technicians. All additional menu items are visible.

Menu of Pelletronic Touch after entering the code:

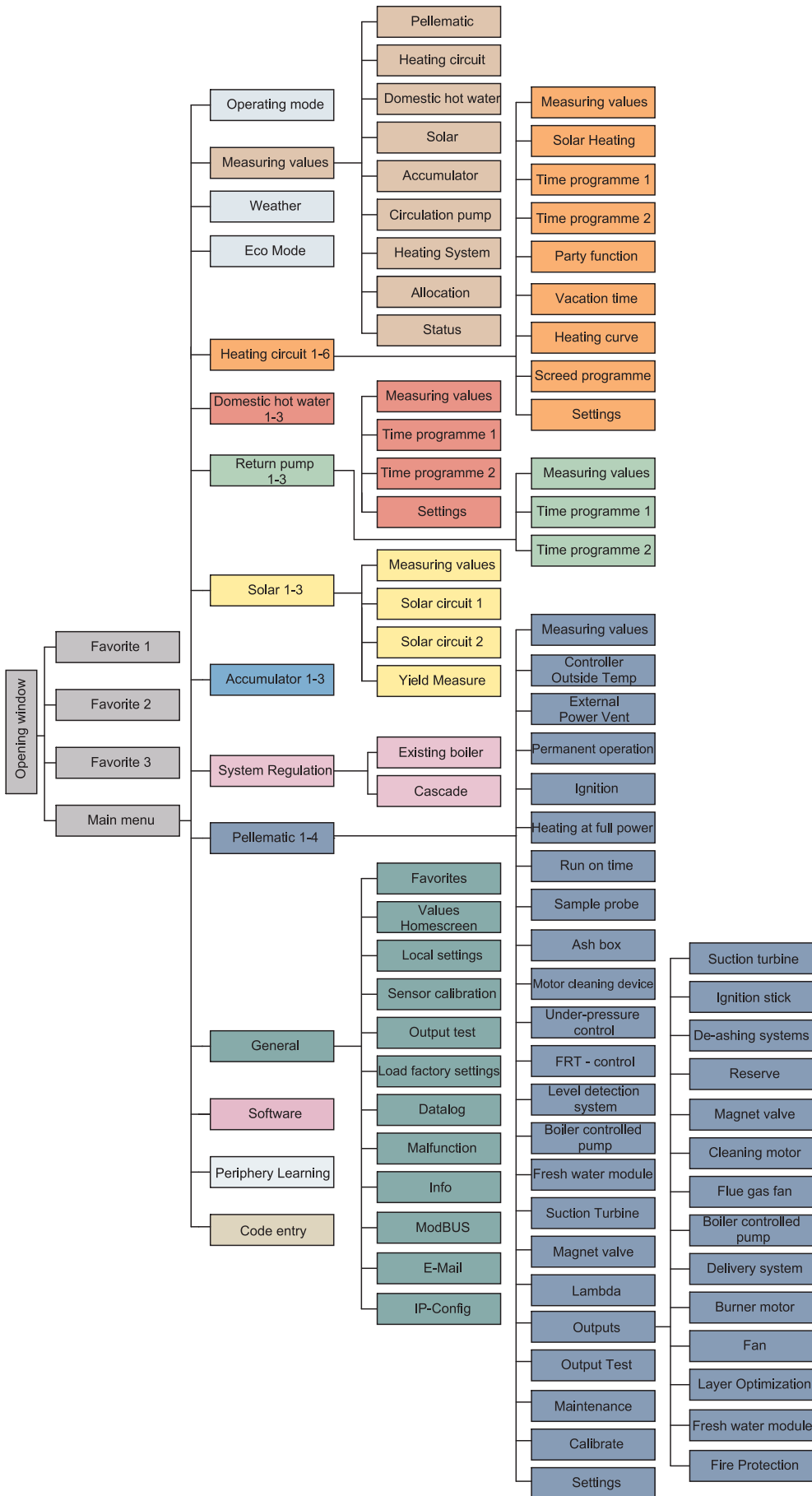

13.2.8 Periphery Learning

In the menu item **Periphery Learning** some basic data of the system components must be entered. All relevant basic settings of the system components (e.g. Boiler type) are thereby loaded.

NOTICE

Make Customer-specific settings and system-specific parameter settings of the boiler controller only AFTER finishing the process Periphery Learning.

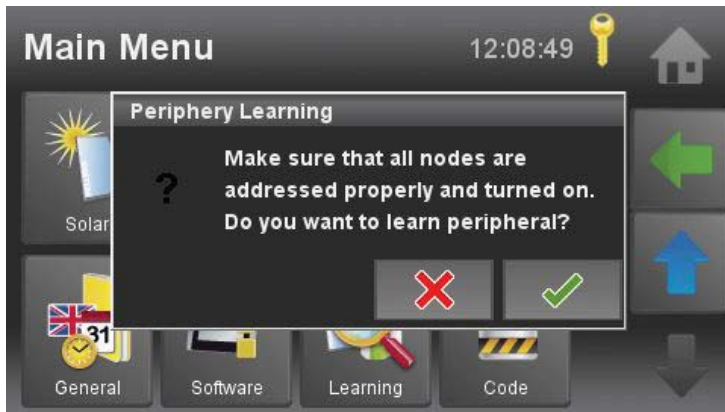

First a warning dialog box opens.

Note:

After confirmation by pressing the button a return is no longer possible.

A finger pressure on the button  takes you to the input field Periphery Learning.



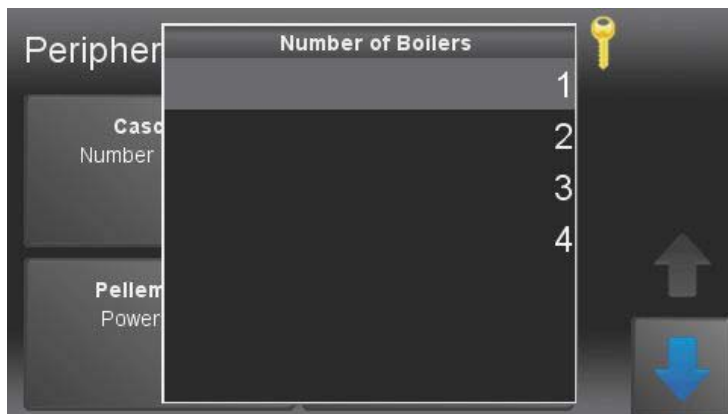
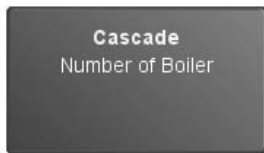

Number of Boilers:

A finger pressure on the appropriate button confirms the set value and takes you back to the input field Periphery Learning.

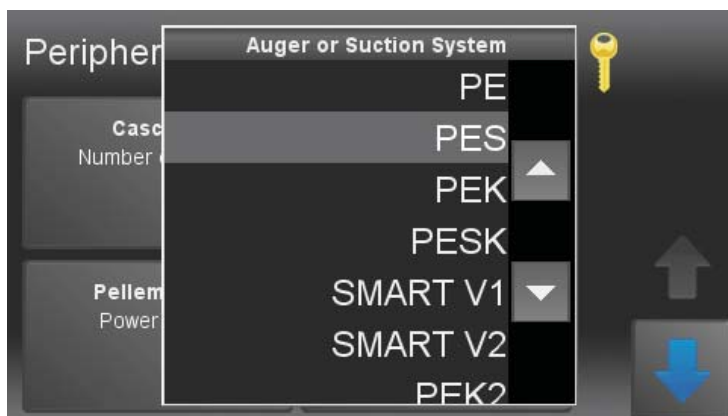
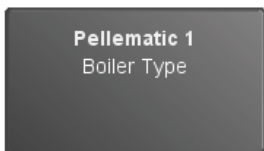

Auger- or Suctionsystem:

- **PE** = Auger system
- **PES** = Suctio system
- **PEK** = Auger system with condensing heat exchanger
- **PESK** = Suction system with condensing heat exchanger
- **SMART V1** = Stratified storage tank with integrated pellet burner, version to May 2013
- **SMART V2** = Stratified storage tank with integrated pellet burner, 14 kW version since June 2013
- **PEK2** = Suction system with condensing heat exchanger

On the rear side of the boiler is the data plate located. On this data plate the boiler type is specified.

A finger pressure on the appropriate button confirms the set value and takes you back to the input field Periphery Learning.

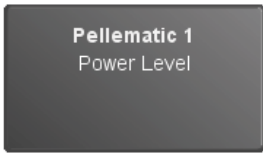

Boiler performance:

Enter the Boiler power rating. On the rear side of the boiler is the data plate located. On this data plate is the rated heating power specified.

A finger pressure on the appropriate button



confirms the set value and takes you back to the input field Periphery Learning.

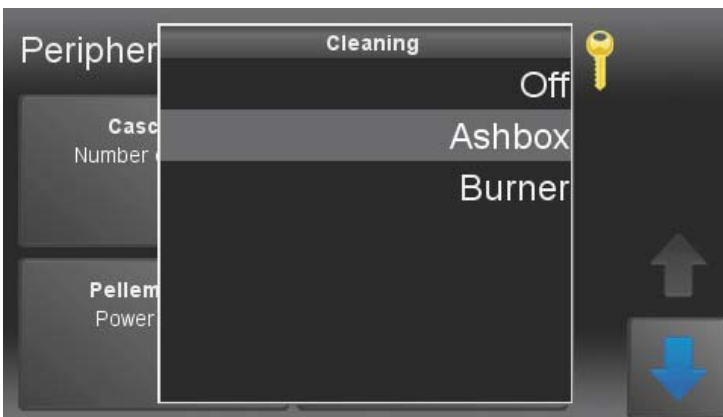
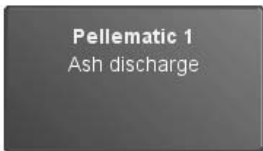

Cleaning:

- **Off**= no automatic de-ashing system and an automatic burner plate cleaning system exists.
- **Ashbox**= an automatic de-ashing system exists.
- **Burner**= an automatic burner plate cleaning system, but WITHOUT automatic de-ashing system

A finger pressure on the appropriate button confirms the set value and takes you back to the input field Periphery Learning.

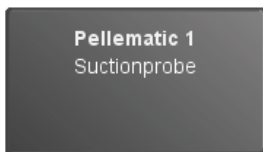

Note:

Only available if a switchbox exists in the system.

One boiler is supplied by several fuel transport augers, flexi tanks or suctionprobes.

Suction probe mode:

- **Off**: No switchbox available
- **Suctionprobe**: Switchbox with suctionprobes
- **Auger**: Switchbox with fuel transport augers or flexi tanks

A finger pressure on the appropriate button confirms the set value and takes you back to the input field Periphery Learning.

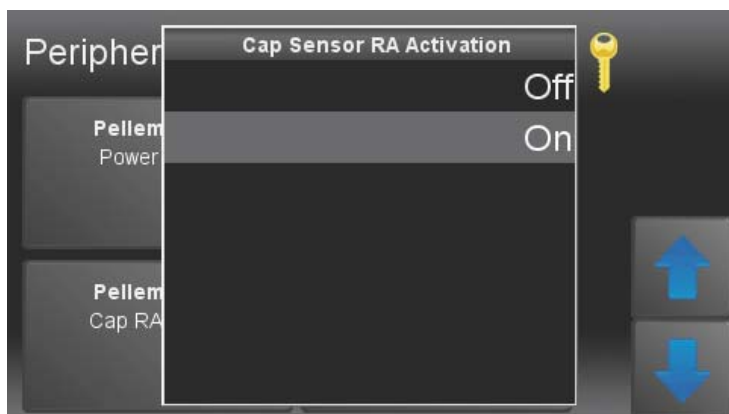

Cap Sensor RA Activation:

- **Off**= no Cap Sensor RA exists = suction system
- **On**= Cap Sensor RA exists = auger system or suction system PES 121000 - 191000 BTU

A finger pressure on the appropriate button confirms the set value and takes you back to the input field Periphery Learning.

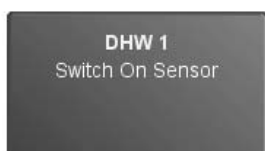

Note:

Displayed only if a accumulator exists.

- **DHW**= DHW sensor
- **TPO**= AC upper sensor
- **TPM**= AC middle sensor
- **TPU**= AC lower sensor

A finger pressure on the appropriate button confirms the set value and takes you back to the input field Periphery Learning.

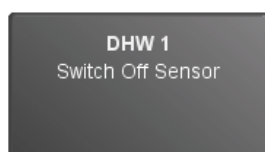

Note:

Displayed only if a accumulator exists.

- **DHW**= DHW sensor
- **TPO**= AC upper sensor
- **TPM**= AC middle sensor
- **TPU**= AC lower sensor

A finger pressure on the appropriate button confirms the set value and takes you back to the input field Periphery Learning.

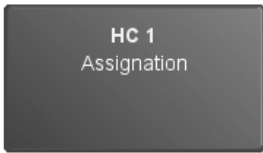

Note:

Displayed only if a accumulator exists.

- **Boiler**= The feeding of the heating circuit occurs directly from the boiler
- **ACC1**= The feeding of the heating circuit occurs from the accumulator

A finger pressure on the appropriate button confirms the set value and takes you back to the input field Periphery Learning.

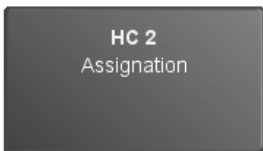

Note:

Displayed only if a accumulator and a second heating circuit exists.

- **Boiler**= The feeding of the heating circuit occurs directly from the boiler
- **ACC1**= The feeding of the heating circuit occurs from the accumulator

A finger pressure on the appropriate button confirms the set value and takes you back to the input field Periphery Learning.



Assignment heating circuits 3-6

If additional heating circuits exists in the system and have been addressed, then additional buttons for Assignment heating circuit 3,4 etc. are displayed.

The assignment occurs in the same way as described above.

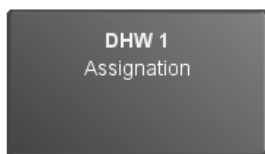
**Note:**

Displayed only if a accumulator exists.

- **Boiler**= The feeding of the heating circuit occurs directly from the boiler
- **ACC1**= The feeding of the heating circuit occurs from the accumulator

A finger pressure on the appropriate button confirms the set value and takes you back to the input field Periphery Learning.

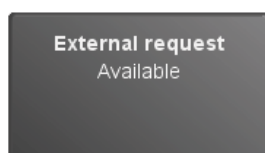
**Note:**

Only activate this function, if a external heat request (e.g. from external heating controller) should be transmited to heating controller Pelletronic Touch.

Mode:

- **Off**= no external request available
- **On**= external request available

A finger pressure on the appropriate button confirms the set value and takes you back to the input field Periphery Learning.

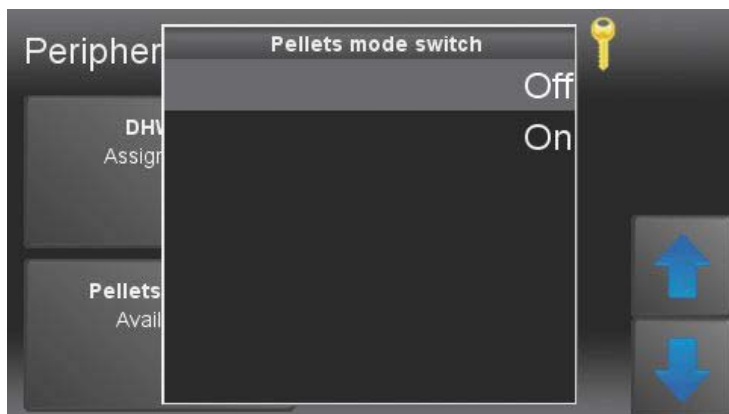
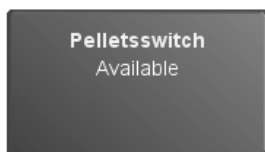
**Note:**

This function is only possible if several boilers exist in the system.

Mode:

- **Off**= no Pelletswitch exists
- **On**= Pelletswitch exists - only possible with a cascade system

A finger pressure on the appropriate button confirms the set value and takes you back to the input field Periphery Learning.

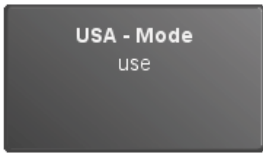

Note:

This function is only possible if you use a burner control unit without heating controller to regulate domestic hot water and heating circuits.



USA Mode:

- Off: USA Mode not used
- On: USA Mode active

A finger pressure on the appropriate button confirms the set value and takes you back to the input field Periphery Learning.

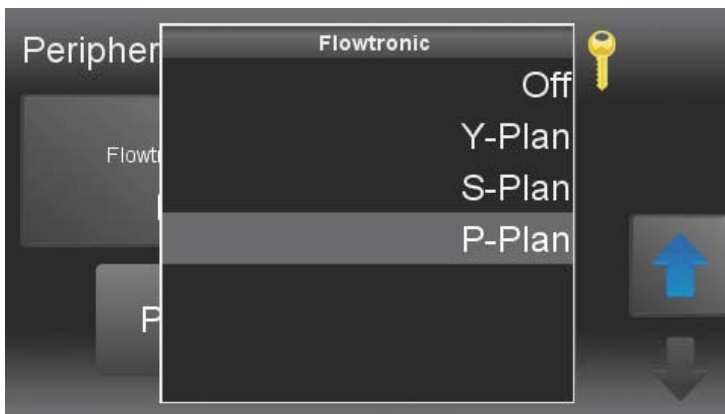
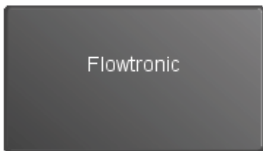

This function must be enabled if a heating circuit and a domestic hot water circuit are operated without a heating controller. The room temperature is regulated using a bus, touch screen or analogue remote control. The DHW temperature is regulated with a sensor at boiler controller plug-in position R2.

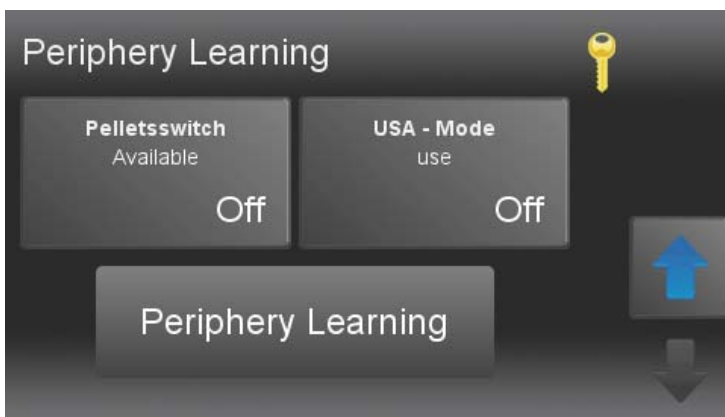

A finger pressure on the appropriate button confirms the selected data and takes you back to the main menu.

Note:

After a new periphery learning if the system has been operating, e.g.:
 -after **Software updates** or
 - **changings in the system** (installation of an additional boiler,...) ,
 the **parametersettings** on the boiler controller (FRT-regulation, ignition-parameters, suction-interval, etc.) will be set to **factory set** and have to be adjusted again.

13.2.9 Flowtronic

Flowtronic can be activated in **Periphery Learning**.



Choose the appropriate function.

- Off
- Mixer
- Sliding
- Sliding w. valve

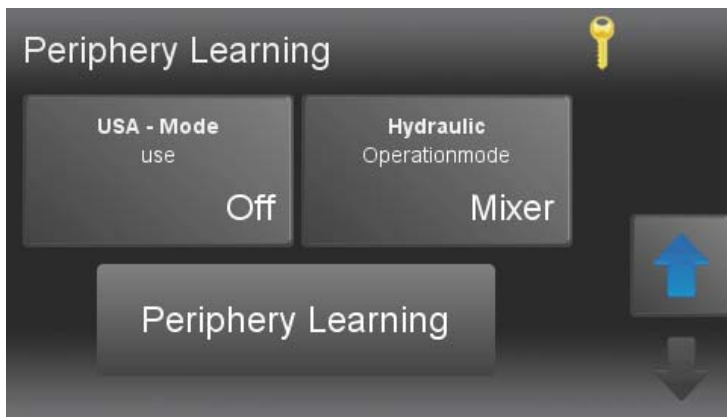

A finger pressure on the appropriate button confirms the selected data and takes you back to the main menu.

In the main menu 1 additional **heating circuit menu** and 1 additional **DHM menu** are displayed.

Regulation results from **set temperature** plus/minus **hysteresis**.

Note:

If an external sensor is connected, the set heating limits are active.

13.3 Mode

In the menu item Mode you can see the mode of your heating system and the mode of of the heating circuits, domestic hot water and solar.



Overview of the operating modes

- Heating Plant
- Heating system 1-6 .
- Domestic hot water 1-3
- Solar 1-3

Choose the operating modes and make settings.

13.3.1 Operation mode

The operation mode of the **whole system** is set in this menu

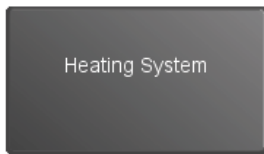

- **Off**
The operating mode of all system components like heating circuits and DHC are INACTIVE. Frost protection is ACTIVE.
- **Auto**
The op. mode of all system components are ACTIVE. Frost protection is ACTIVE.
- **DHC**
The op. mode DHC is ACTIVE. The op. mode of the heating circuits are INACTIVE. Frost protection is ACTIVE.

13.3.2 Operation mode HC 1

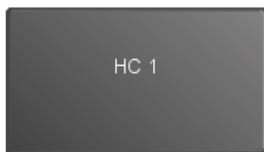

- **Off**
Only frost protection is active.
- **Auto**
The boiler heats within the heating times according to the desired room temperature.
- **Heat**
The boiler heats permanently according to the desired room temperature.
- **Set back**
The boiler heats permanent according to the respective set back temperature.

13.3.3 Operation mode HC 2-6

If more heating circuits are available and adressed, more buttons for **allocation HC 2,3** etc. are displayed.

Note:

The allocation works like described above.

13.3.4 Operation Mode DHW

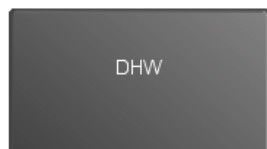

- **Off**
The system fulfills frost protection and keeps the DHW above 8°C.
- **Auto**
The system heats the water within the DHW-time programme up to the DHW desired temperature. Outside the DHW-time-programme the system heats the water to watertemp. min.
- **On**
The system heats the DHW permanently to the desired DHW-temperature.

13.3.5 Operation mode solar

Note:

This menu item is only displayed if a solar system (collector) exists.

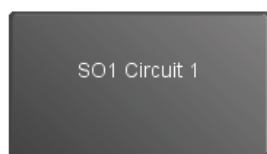

- **Off**
No charge.
- **On**
Charge happens when the collector-temp minus collector hysteresis is higher than the temperature of the ACC Sensor below and as long as the ACC-Temperature Max is not reached. Charge from the collector to the ACC is enabled.

13.3.6 Operation mode Pellematic

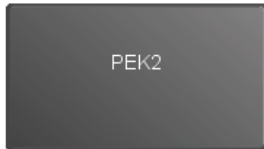

- **Off**
Any burner demand is ignored.
- **Auto**
Burner demand happens across the heating controller.
- **On**
Permanent Burner demands to the boiler (like bridge on BR 1)
Shut down across the regulation of the switch off temp.



Back to **Main menu**.

13.4 Measuring values



In this menu no adjustments can be set.
In the various sub menu items measuring values and adjusted settings are displayed.

- current values
- desired values
- input (sensors)
- output (pumps, mixers and motors)

Note:

Only values of components that exist in the system are displayed.

13.5 Weather



Choose **Settings** (), to enter your location.



Enter location and country. If the specified location is not found, enter a larger, nearby place.

Search with the following details:

- Postal code location, country
- Postal code, country
- Location, country



Afterwards, weather data for the next 3 days are downloaded. An icon for the current weather is displayed on the opening window.

Note:

This feature requires an internet connection.

13.6 Eco Mode



With the Eco Mode, the influence of weather forecasts can be defined.

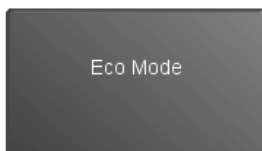

- Off:** Eco mode inactive.
- Comfort:** Set temperature minus ½°C
- Minimum:** Set temperature minus 1°C
- Ecologically:** Set temperature minus 1 ½°C

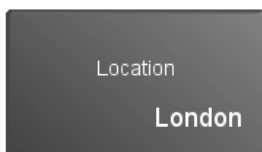

Enter location and country. If the specified location is not found, enter a larger, nearby place.

Search with the following details:

- Postal code location, country
- Postal code, country
- Location, country

Afterwards, weather data for the next 3 days are downloaded. An icon for the current weather is displayed on the opening window.

Note:

This feature requires an internet connection.

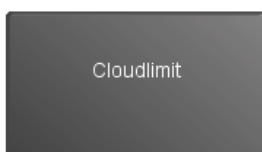

If the cloud is below the threshold, the control assumes that the weather is nice. The threshold can be adjusted in the code level.

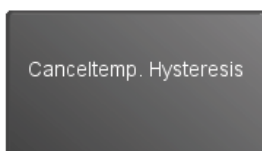

If an outdoor sensor is mounted, a **Canceltemperature** can be set.

If the actual temperature falls below of the forecast temperature by the specified hysteresis, the eco function is disabled until the next valid forecast. (Update every hour).

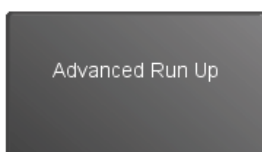

To consider the heating reaction time a **hold-back time** can be set (default = 120 min).

The forecast is always active until the endtime. When the endtime is exceeded, the next day is used for the forecast.

Before the endtime, the forecast influences the present day. After the endtime the forecast for the next day is created.

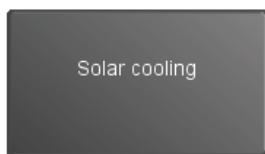

To increase the solar yield, the function „**Solar cooling**“ can be activated. This function activates the solar pumpe between 4 and 6 A.M., until accumulator low temperature falls below accumulator max temperature minus hysteresis minus 1°C. This should ensure that the acumulator is receptive again.

Note:

This function is only available in fair weather.

Cur. temperature

Current temperature according to forecast.

Cur. clouds

Current clouds in % according to forecast.

Average temperature today / tomorrow

Calculated temperature for the forecast period

Average clouds today / tomorrow

Calculated clouds for the forecast period

Sunrise / sunset

Time at sunrise or sunset

Starttime/ Endtime

In this time frame, the Eco Mode affects the heating settings.

Last update

Time of last update of the forecast.

Back to Main menu



13.7 Heating Circuit

Appropriate to the amount of existing heating circuits, for every HC a menu item (Icon) is displayed.



Heating circuits settings has following menu items:

- Operating Mode
- External request
- Room Temp Heating
- Room Temp Set Down
- Time Selection
- Display name
- Values
- Time 1
- Time 2
- Party
- Vacation
- Heating curve

In this submenu, you can set customer-specific adjustments.
Detailed information are in the Manual for the End User.



More adjustments for the ÖkoFEN Service technician:

Flow Temp Max

Is the upper limit of the flow temperature, even if due to the outside temperature a higher flow temperature would be needed.

Flow Temp Min

Is the lower limit of the flow temperature, even if due to the outside temperature a lower flow temperature would be needed.

T-increase

This is the temperature value, which is added to the flow temperature set. If the calculated flow temperature set is 60°C and the reinforcement is 5°C, the accumulator temperature set is 65°C. If the measured boiler temperature or the temperature of accumulator sensor high (TPO) is lower, the heating controller initiates a burner request.

Mixer Present

Choose the type of heating circuit

- HC with a mixermotor
- direct HC

Mixer Open

Is the opening duration of the mixer.

Note:

The relation of **mixer Open-Off-Close** allows you to adjust the mixer to the inertia of the hydraulic system.

Mixer Off

is the break time of the mixer.

Note:

The relation of **mixer Open-Off-Close** allows you to adjust the mixer to the inertia of the hydraulic system.

Mixer Close

Is the close time of the mixer.

Note:

The relation of **mixer Open-Off-Close** allows you to adjust the mixer to the inertia of the hydraulic system.

Control Range BT

This control range starts with the **boiler temp min** and ends with the **boiler temp min + controll range BT**. In the control range the switch on time of the mixer shortens dynamically. That means, the closer the boiler temp gets to the **boiler temp min**, the shorter is the opening duration of the mixer.

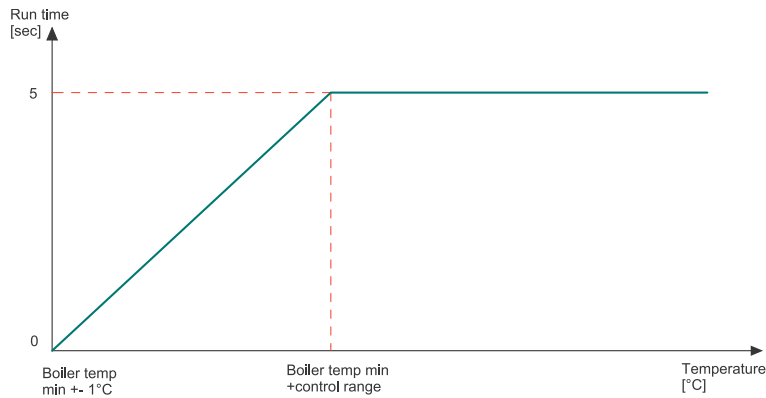

Control Range Flow

This control range is operating from the calculated **flow-setpoint-temperature** upwards and downwards. In the control range the opening and closing duration of the mixer are changing dynamically to avoid a oscillation of the hydraulic system. That means, the closer the measured flow temp is to the calculated flow temp, the shorter is the opening- or closing duration of the mixer.

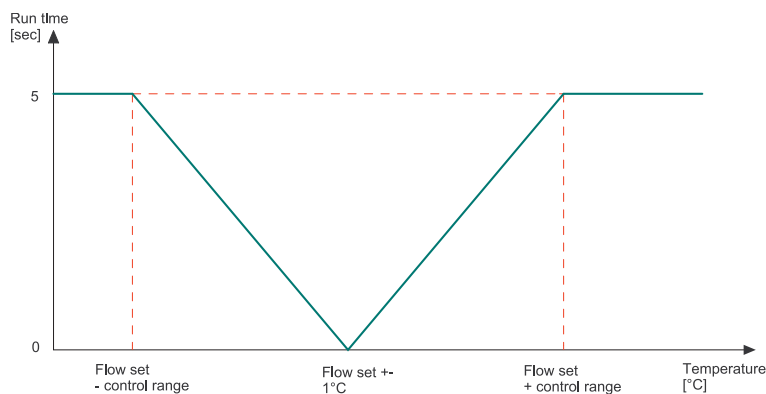

Boiler Temp Curve
Temp Rise

The minimum value of the temperature rise at the boiler sensor.

A dark grey rectangular box with rounded corners containing the text "Boiler Temp Curve" in bold and "Control Range" below it.

Boiler Temp Curve
Control Range

Is the temperatur area (from BT min + 1°C to BT min +control range) in which the curve regulation is active.

The BT developing causes a continous rise of the BT, in which the controller regulates the heat taking over the mixer.

Note:

The BT developing is only active, if he gets adjusted to a HC.



Back to **Main menu**.

13.7.1 Screed programme

The screed programme may be operated up to 31 days. A desired flow temperature must be adjusted for each individual day. These temperatures are constant and not dependent on outside temperature or room thermostat settings. The function is switched off automatically at the end of the programme and the heating circuit reverts to the previous operating mode.

NOTICE

Damages to the screed by too high temperatures.
 Only use this programme in conjunction with a pump interlock switch positioned on the flow from pump to under floor central heating – this must be set to the max. safe temperature for the conditions of the floor. No liability is accepted by the Pelletronic supplier for damage to floors or sub floors.
 Continuous power supply is required to the controller to maintain the settings for this programme.
 Only use programme temperatures approved by the UFCH and flooring suppliers.

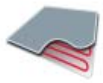

Screed programme is in the menu Heating circuit.

Switch on the Screed programme. At the end of the screed programme the screed programme switches off itself automatically and returns to the previous mode.

Enter the number of heating days. There are 0-31 heating days possible. According to the number of heating days a Flow temperature set appears for every heating day. Select every single day and adjust the Flow temperature set. The pre-set Flow temperature set per day is 20 °C.

With you get to all other days.

13.8 Solar Heating



This function should allow a more efficient use of solar energy (AC energy). Each heating circuit receives a new button.

Note:

The menu Solar Heating is only available if a accumulator is allocated.

13.8.1 Menu Solar Heating

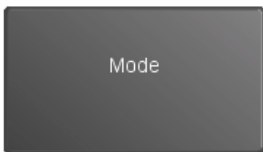

Off: Solar Heating is disabled.
Time Program: If the accumulator temperature is above the switch on temperature during the set heating times, the heating circuit is heated until the switch off temperature is reached.

Note:

Effects when Eco-mode is activated:

If the weather forecast predicts bad weather (little solar gain), the function solar heating is canceled.

Solarpump: Heating program only active when solar pump is active.

Note:

If the mode solar pump is activated, the associated solar circuit can be selected. While the solar pump is active and the accumulator reaches the switch on temperature, the heating function is carried out until the switch off temperature is reached.

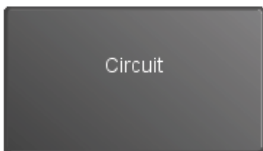

The values are calculated from hot water temperature plus hysteresis.

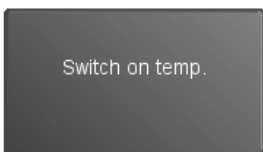

The values are calculated from hot water temperature plus hysteresis.

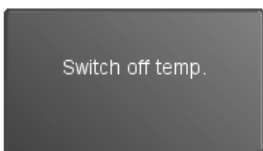

The values are calculated from hot water temperature plus hysteresis.

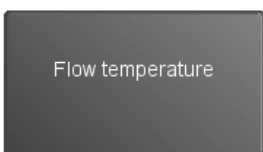

If temperature on accumulator sensor high rises above the switch on temperature, flow temperature is given to the heating circuit until it falls below the switch off temperature.



It is heated only during the set time.

Note:

If Eco-mode is active durring solar heating, it is only used when fair weather is predicted.

13.9 DHW settings



DHW settings has following menu items:

- Operating Mode
- External request
- Water Temp Set
- Water Temp Min
- Time Selection
- Display name
- Values
- Time programme
- Time 1
- Time 2



In this submenu, customer specific adjustments can be set. Further information therefore is to be found in the Manual for the End User.



Further adjustments for the Service technician.

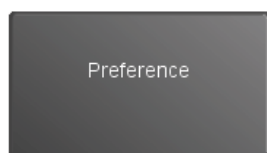

Preference

Hot water preference can be turned on or off.

If hot water preference is turned on, accumulator is heated up to the hot water set temperature. Afterwards the boiler supplies the heating circuits.

If hot water preference is turned off, the boiler supplies accumulator and heating circuits paralell.

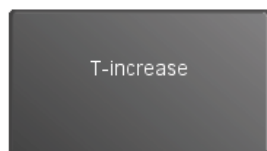

T-increase

The **reinforcement** is the temperature which is added to the **DHW-setpoint temp.** With a **desired DHW temperature** of 60° C and a reinforcement of 5°C the temperature in the buffer is 65°C. Is the measured **Boiler Temp** on e.g. the **accumulator sensor above** lower, a burner demand will be sent by the heating controller.

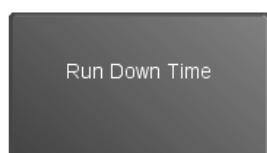

Run Down Time

This function is set in minutes and determines the run on time of the DHW pump. This allows residual energy in the boiler or accumulator to be transferred to the DHW cylinder.

E.g. 10 min or if the boiler temp is lower than DHW cylinder, whatever occurs first.

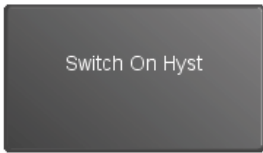

Maintains the temperature of the DHW within this range during a timed or manual ON period.
 Only functions when the operating mode of the DHW has to be ON or AUTO.
 If the operating mode is set AUTO, there has to be a demand for the burner.

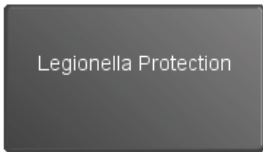
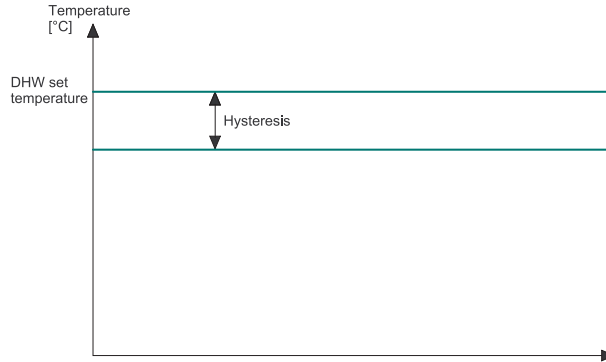

Raises DHW cylinder temperature to Legionella pasteurisation temperature 65° on a chosen day each week. You can deactivate this function.



Back to **Main menu**.

13.10 DHW Return Pump settings



DHW Return pump settings has following menu items:

- Mode
- Switch Off Temperature
- Switch On Hysteresis
- Pump Release Temp
- Display name
- Values
- Time 1
- Time 2



In this sub menu item, customer-specific adjustments can be set. Therefore detailed information is to be found in the manual for the End-user.

Further adjustments for the servicetechnician

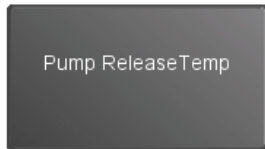

The DHW temperature must be higher than the **Pump release temperature**, otherwise the DHW return pump does not switch on.

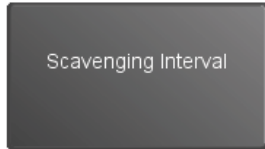

If the DHW Return Pump is not active although it is in the **AUTO** mode, the pump runs according to the **Flushing interval** for refreshing the return-flow sensor.

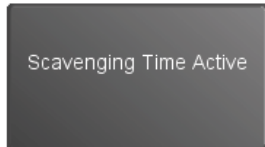

Enter the **Scavenging Time Active**, which the DHW Return Pump must run until the end of the scavenging interval for getting correct values from the return-flow sensor.



Back to **Main menu**.

13.11 Solar settings

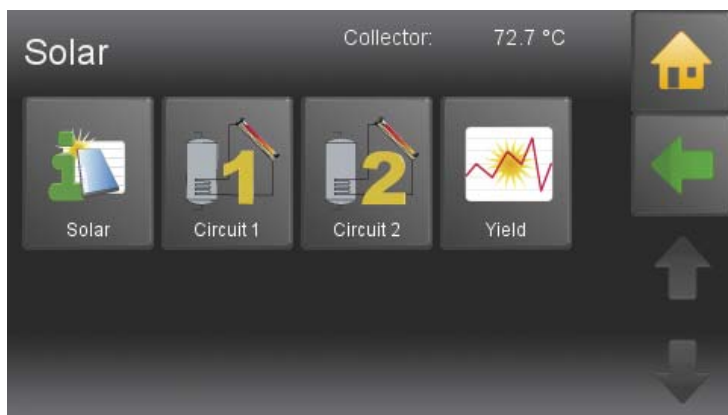

Note:

The button **circuit 2** is only displayed if a second solar system exists.



In the menu item measuring values no settings can be adjusted. Measuring values and adjusted settings are displayed.



The menu item Circuit 1 has following sub menu items:

- Op Mode
- ACC Temp Max
- ACC Hysteresis
- Collector Hyst On
- Collector Hyst Off
- Scavening
- Prio
- Display name

In this sub menu customer-specific adjustments can be set.

Therefore detailed information is to be found in the user Manual for the End User

Settings for the Service technician:

Limit Sensor

If the temperature of the limit sensor is higher than the set temperature max, the solar circuit pump switches off.

Solar Switch Off
Coll Overheating

If the collector reaches the collector overheating temperature, the solar pump turns off.

Solar Switch Off
Coll Overheating Hyst

The solar circuit pump switches on again when the collector temperature falls below the Coll Overheating minus Coll Overheating Hyst temperature.

Pump
Pump/Switching Valve

You can choose for every solar circuit between solar pump and diverter valve.

Note:

If the **diverter valve** is chosen, the speed controller, pump type and parallel operation are hidden.

Pump
Pump Type

The menu **Pumptype** contains the following entries:

Asynchronous: Asynchronous pump – direct output 230VAC on/off

Async.Regulated: Asynchronous pump – pulsed output 230VAC

Heating Efficient: PWM1 - PWM signal inverted

Solar Efficient: PWM2 - PWM direct signal

Note:

If using a high-efficiency pump as **accumulator pump**, the pump of solar circuit 2 can't be speed-regulated.

NOTICE

Wrong selection of the pump type can cause material damage.

Collector Protection
Mode

The collector protection mode can be switched ON or OFF.

Note:

Even if the operation mode of the solar thermal system is OFF, the collector protection is active, provided that it is turned on. This serves to protect the solar thermal system.

Collector Protection
Protection Temp

If the collector protection mode is activated and the collector sensor reaches the protection temperature, the DHW pumps and heating circuit pumps switches on. Further the mixer open till the maximum flow temperature is reached. This process stops if the collector temperature rises until the Solar Switch off / Collector Overheating.

Note:

The collector protection must be set lower than the Solar Switch off / Collector Overheating.

Collector Protection
Protection Temp Hyst

This process also stops when the collector temperature falls below the collector protection temperature minus protection temperature hysteresis.

Scavenging
Mode

You can switch scavenging ON and OFF. The scavenging process compensates different temperatures in the solar circuit.

Scavenging
Pause Time

With Rest Time and Run Time you set the scavenging interval.

Scavenging
Run Time

With pause time and run time the scavenging interval is set.

Scavenging
Collector Temp Min

If the collector temperature is below the collector temperature minimum, the scavenging process is not performed.

Scavenging
Start Time

With the Start Time you set the beginning of the scavenging process. Start and Stop time are avoiding an unnecessary operation of the solar circuit pump.

Scavenging
Stop Time

With Start- and Stop-Time the end of the scavenging is set. Start- and Stop-Time avoids unnecessary running of the solar circuit pump.

Prio
Mode

The priority switching serves the efficient energy utilization in case of 2 solar circuits

It sets the priority (order) of the solar circuits.

PRIO ON can only be allocated to 1 solar circuit. Requirements from the solar circuit PRIO ON are completely fulfilled first.

Prio
Run Time

Set the solar pump pulse programme for solar circuit PRIO 2.

Only for solar circuit PRIO 2 it is necessary to set the solar pump pulse programme. After the scavenging period of solar circuit PRIO 2 follows the scavenging interval of both solar circuits.

After the scavenging interval follows the scavenging time.

During the scavenging time the solar circuit checks, if there is a new demand for PRIO 1 or not.

If there is a demand for solar circuit 1, the pump runs, if not the scavenging period of solar circuit 2 starts.

If during the scavenging period of solar circuit 2 there is a demand from solar circuit 1, it will be immediately fulfilled.

Prio
Pause Time

Prio
Scavenging Time

Note:

PRIO Runtime, PRIO break time and PRIO scavenging time are only adjustable if **PRIO Mode** is set to **Off**.

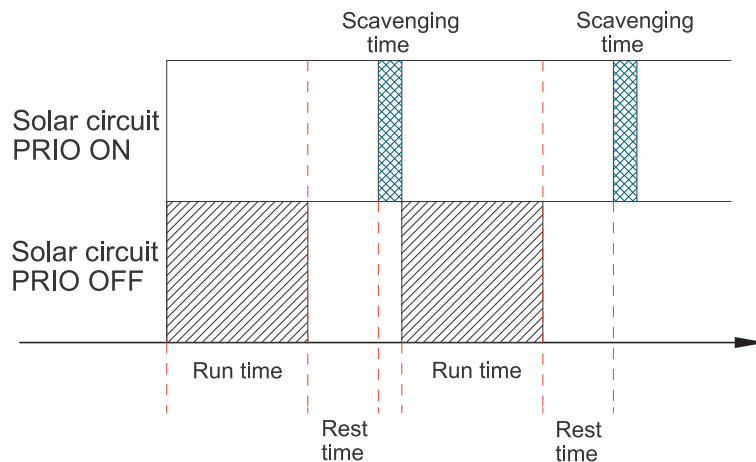

Parallel Operation
Temp Difference

This setting only appears with two solar circuits with two pumps.

The procedure is the same as with one pump. Additionally both pumps can run in parallel. If the temperature difference between collector and TPU lower sensor from the solar circuit with PRIO A is higher than the temperature difference, both solar circuits run parallel. The parameter value is only in solar circuits with PRIO A visible and adjustable.

Timing chart for **2 solar circuits with 1 pump and 1 diverter Valve** and **2 solar circuits with 2 pumps** (solar circuit 1 ... Prio 1, solar circuit 2 ... Prio 2):

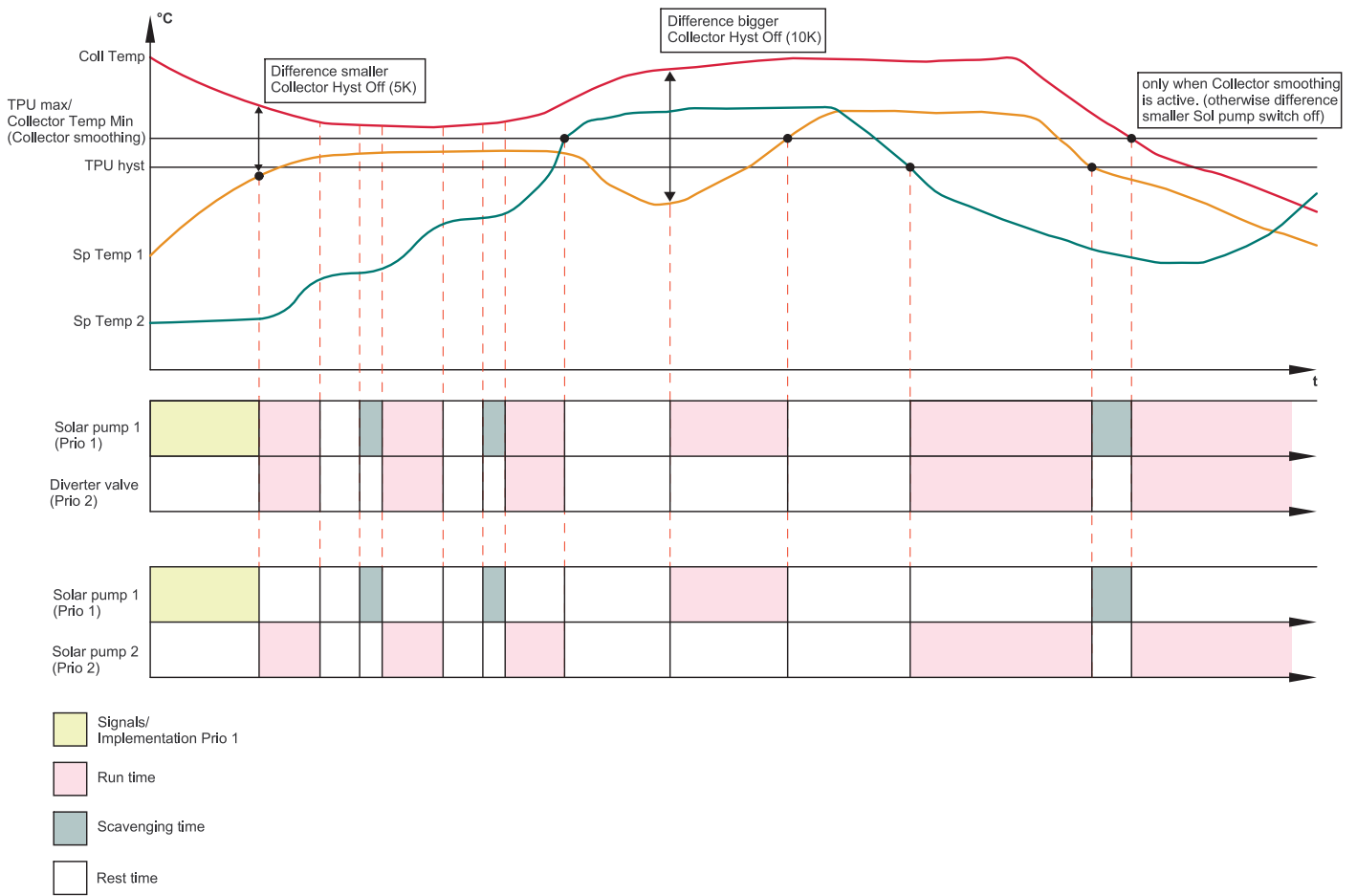

Note: If the difference temperature in parallel operation (standard 25°C) is exceeded, both solar pumps are active.



Back to the menu **Solar**.



If a solar circuit 2 exists in your system, you can adjust your settings in these menu items.

Note: The settings can be adjusted like in **solar circuit 1**.

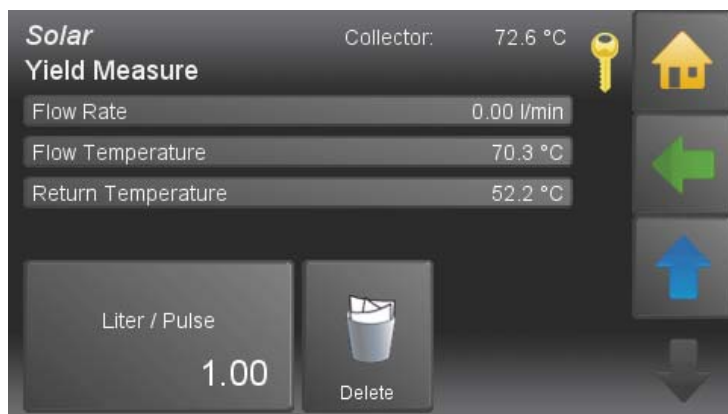

In this menu item the measuring values of the solar system are displayed.

Further adjustments for the Servicetechnician:

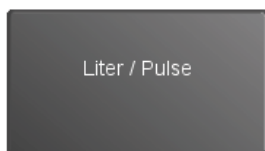

Adjust this setting to the flow rate. The basic setting 1,0 l / min corresponds to the flow rate of the profit set.



Adjust this setting to the flow rate. The basic setting 1,0 l / min corresponds to the flow rate of the profit set.

Note:

Remove the date and the actual gain during the startup by pressing the Delete button.



Back to the menu **Solar**.

13.12 Accumulator settings



Accumulator has following menu items:

- ACC Temp Min On
- ACC Temp Min Off
- Discharge Pump On Temp
- Pump Depends on Require
- Pump type
- Pump Speed Controller
- Pump Switch Off Hyst
- Pump Run On Time
- Pump Control Range



For each heating circuit you can regulate one accumulator. You can operate a maximum of three heating controllers in a system.

Therefore the number of accumulators is limited to 3. Connect the sensor of the accumulator to the heating controller. Then perform **Periphery Learning**. In **Periphery Learning** you assign to the participants (heating circuit or DHW) an accumulator.

Make further adjustments in the menu **Accumulator**.

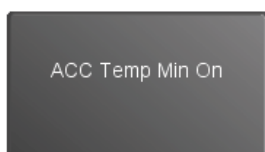

If the temperature at the TPO (AC upper sensor) falls below the specified value of **ACC temp min**, a burner demand occurs to load the accumulator until the TPM (AC middle sensor) reaches the limit.

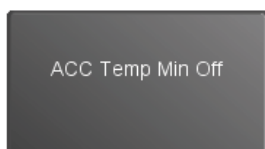

The accumulator loads as long as the adjusted value of **Accumulator Temp Min Off** is reached.

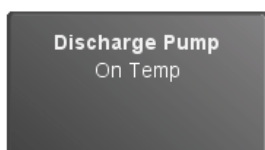

If the temperature on the **accumulatorsensor rises** above the **Discharge Pump On Temp**, all pumps allocated to the participants are set to active.

Accumulator Loading P...
Depends on Require

On: The accumulator is loaded, the accumulator is not loaded further.
Off: The accumulator is loaded, but the accumulator is charged further, as long as the accumulator temperature does not exceed the accumulator temperature or the boiler temperature does not exceed the Pump On Temperature.

Pump
Pump Type

The menu **Pump Type** contains the following items:

- Asynchronus:** Asynchronus pump – direct output 230VAC on/off
- Async.Regulated:** Asynchronus pump – pulsed output 230VAC
- Heating Efficient:** PWM1 - PWM signal inverted
- Solar Efficient:** PWM2 - PWM direct signal

Note:

When using an A-class pump as a **accumulator pump**, the pump can not be regulated from solar circuit 2.

NOTICE

Material damage when wrong pump type is selected.

Accumulator Loading P...
Switch Off Hyst

The pump switches off after the temperature falls under the **discharge pump on temp** minus the **accumulator pump switch off hyst**.
The Switch off hyst prevents from a frequent on and off of the pump.

Accumulator Loading P...
Run Down Time

The accumulator pump run down time after the switch off of the burner demand – in minutes.

Accumulator Loading Pu...
Control Range

The **Accumulator Pump control range** at speed controller.
The Accumulator pump starts at the pump on temp (see chapter System Regulation) with 30% performance. The performance rises parallel til the **pump free temp** + **control range** is on 100%.

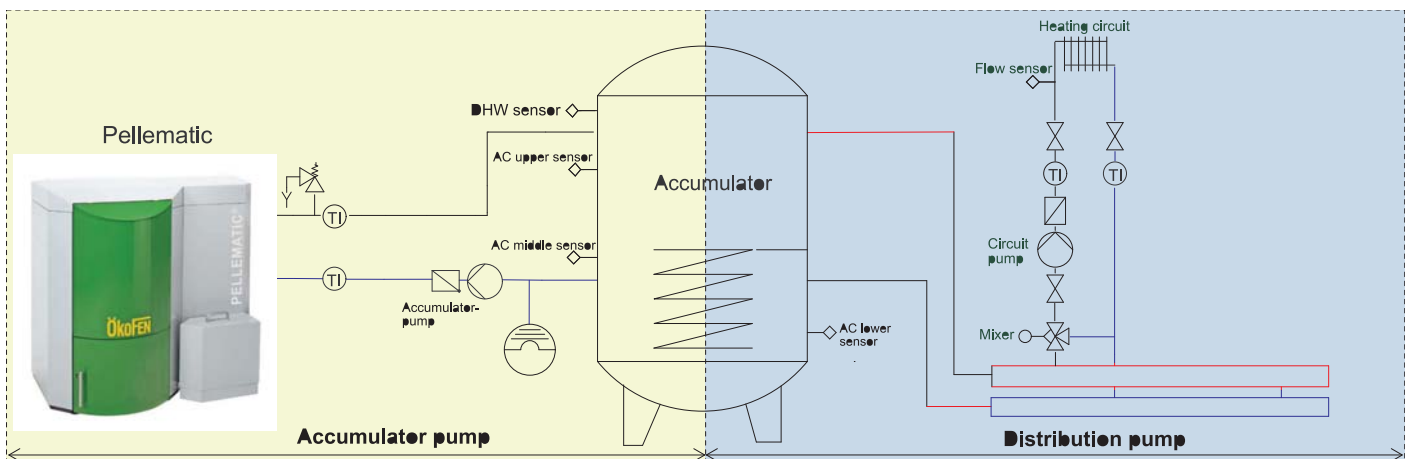

Note:

The spot for the accumulator pump is on the heating controller on **X32**. (PLP)



Back to **Main menu**.

13.13 System Regulation

In **Sys Regulation** you can input the parameters of the whole heating system.

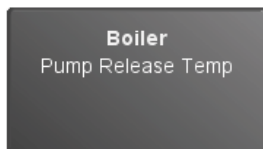
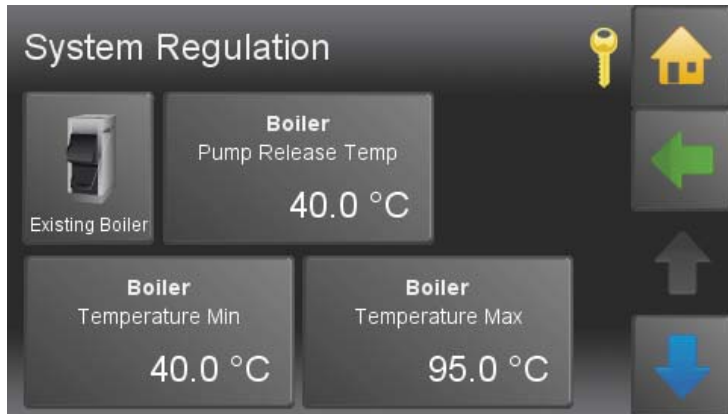

If the Boiler temperature reaches the **Boiler Pump On Temp**, the pumps are given free.

Note:

The temperature should be at a minimum of 60°C (for avoiding condensate in the boiler).



The control range of the mixer starts at this temperature and ends at the **boiler min temp** plus **BT controll range**.

In case of a burner demand, at least that temperature is required as boiler setpoint temperature.

Note:

The temperature should be at a minimum of 60°C (for avoiding condensate in the boiler).

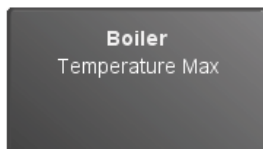

If the boiler or the Accumulator reservoir reaches the **system temp max**, all heating circuit pumps are activated for transporting the heat energy out of the boiler. This process ends, if the boiler temp falls under the **system temp max** minus **boiler superelevation**.



This function sets, for which periode the outside temperature should be measured.
0 = no message



If the outside temperature falls below the **Frost Protection – Protection Temp** the heating circuits are scavenged periodically. Default is 4°C, adjustable from -20 to 4° C.

Note:

The Frost Protection is additionally always active: i.e. If the temperature of the **Flow sensor** or the **AC upper sensor** is 8°C, the burner demand activated.



If the outside temperature falls below the **Frost Protection - Protection Temp** the periodically Scavenging occurs according to Scavenging Time and Pause Time. Default values: Scavenging Time 5min and Pause Time 60 min.

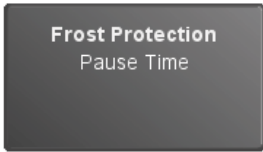

Note: If the pump is activated because of other reasons, the Pause Time starts again.



Back to **Main menu**.

13.13.1 Cascade settings

Conditions for a cascade:

- A cascade system with an accumulator is only possible with accumulator No.1.
- Exisits accumulator No.1, all participants must be assigned to accumulator No.1.
- The accumulator pump must be connected to the boiler.

Periphery Learning

Note:

Prior to the **Periphery Learning**, all participants must be connected properly.

The number of boilers and selection of the switch off sensor in a cascade system with an accumulator must be taken in the menu Periphery Learning.



Number of Boiler

Insert the number of boilers. Peak load boilers count to the number of boilers. Example: 3 Pellematic and 1 Peak load boiler results in a number of 4!

Switch Off Sensor

If an accumulator is present, you can choose the TPO (AC upper sensor) or the TPM (AC middle sensor) for the Switch Off Sensor. If there exists no accumulator in the system, then you do not have this choice.

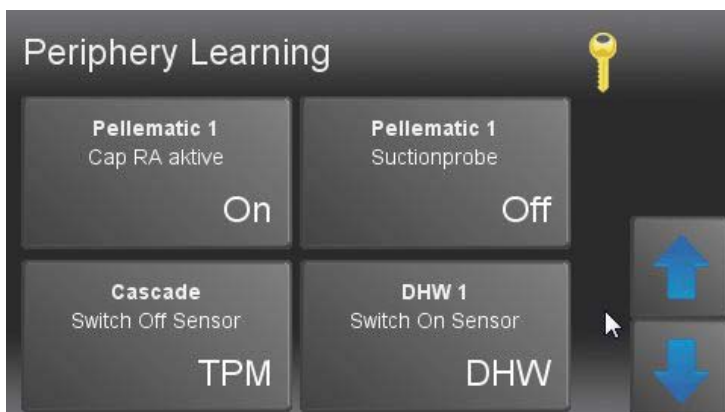

The **cascade** regulates the collective operation from 2 to 4 Pellematic pellet boilers or 3 pellematic pellet boilers and a reserve boiler of another kind.

There exist cascade systems with and without accumulators.



In the windows 1 and 2 no settings can be adjusted.
Measuring values and adjusted settings are displayed.

Cascade		Sequence Change:	3000 min		
		Outside Temp:	-0.3 °C		
Cascade Base			55.0 °C		
Switch On Temp Current			54.1 °C		
Switch Off Temp Current			26.1 °C		
Blocking Time	B1:	0 min	B2:	2 min	
	B3:	32 min	B4:	62 min	
Boiler 1	On:	67.0 °C	Off:	71.0 °C	
Boiler 2	On:	63.0 °C	Off:	67.0 °C	
Boiler 3	On:	58.0 °C	Off:	63.0 °C	

Not adjustable

Cascade Base

The **Cascade Base** is the calculated source temperature for the function of the cascade. It results according to the amount of set values. The Hysteresis is added to the Cascade Base.

Switch On Temp Actual

The Switch on sensor at a accumulator is always the TPO (AC upper sensor)
The Switch on sensor at a hydraulic seperator is the boiler sensor (= coeval the switch off sensor).
The Switch on sensor maesures the **Switch On Temp Actual**.

Switch Off Temp Actual

The Switch off sensor at a accumulator is the TPO (AC upper sensor) or the TPM (AC middle sensor)
The switch off sensor at a hydraulic seperator is the boiler sensor (= coeval the switch on sensor).
The switch on sensor maesures the **Switch Off Temp Actual**.

Delay Time

At first starts only one boiler. Each further boilers start after the Delay Time.
You see the remaining Delay Time of each boiler.

Boiler 1- 4

The boilers are numbered from 1 – 4. The numbering equals to the real boilers numbers. If the font of the boiler 1 is green, it symbolizes a burner demand.
Besides the numbering of the boilers there is the starting numbering. It can be different to the boilers numbering because of the sequence changes. The settings Hysteresis, Delay Time and Delay Temperature refer to the starting numbering of the boiler.



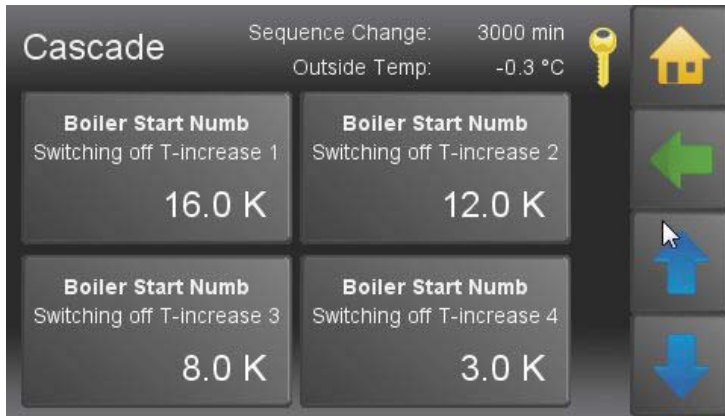

Adjustable

Hysteresis

The setting of the **Hysteresis** refers to the boilers starting numbering. For each starting numbers there is an individually adjustable Hysteresis. The **Hysteresis** enables a gradual ON and turn-OFF of the boilers. See graphic.

Delay Time

The setting of the **Delay Time** refers to the starting numbers of the boilers. Apart from the starting number 1, each starting number has a Delay Time. At first it starts only the boiler with the starting number 1. Every other boiler starts at the end of the Delay Time in which is checked if the boiler or the boilers can fulfil the requirements. With the burner demand of the boiler with starting number 1, all Delay Times starts at the same time.

Delay Temp

The setting of the **Delay Temp** refers to the starting numbers of the boiler. Apart from the starting number 1, each starting number has a Delay Temp. If the outside temperature is higher than the Delay Temp, there is **no** burner demand.

Cascade Base Min

The **Cascade Base Min** is the minimum requirement to the cascade. Falls the **Cascade Base** (is calculated from the set values) falls below the **Cascade Base Min** obtains the **Cascade Base Min**. If there is no requirement, the cascade only activates, if the frost protection function is active (8°C).

Sequence Changes

To load the boilers equally, the starting numbers of the boilers change at the end of the time **Sequence Changes**. The time **Sequence Changes** refers to the actual boiler run time.

Note:

With setting **0**, no Sequence Change is made! It always starts boiler No.1 at first.

Peak Load Boiler

The **Peak Load Boiler** is actually the last boiler (the highest boiler number). It has the highest starting number. The **Peak Load Boiler** is excepted from the sequence change. It is only used for managing energy peaks and always starts at last.

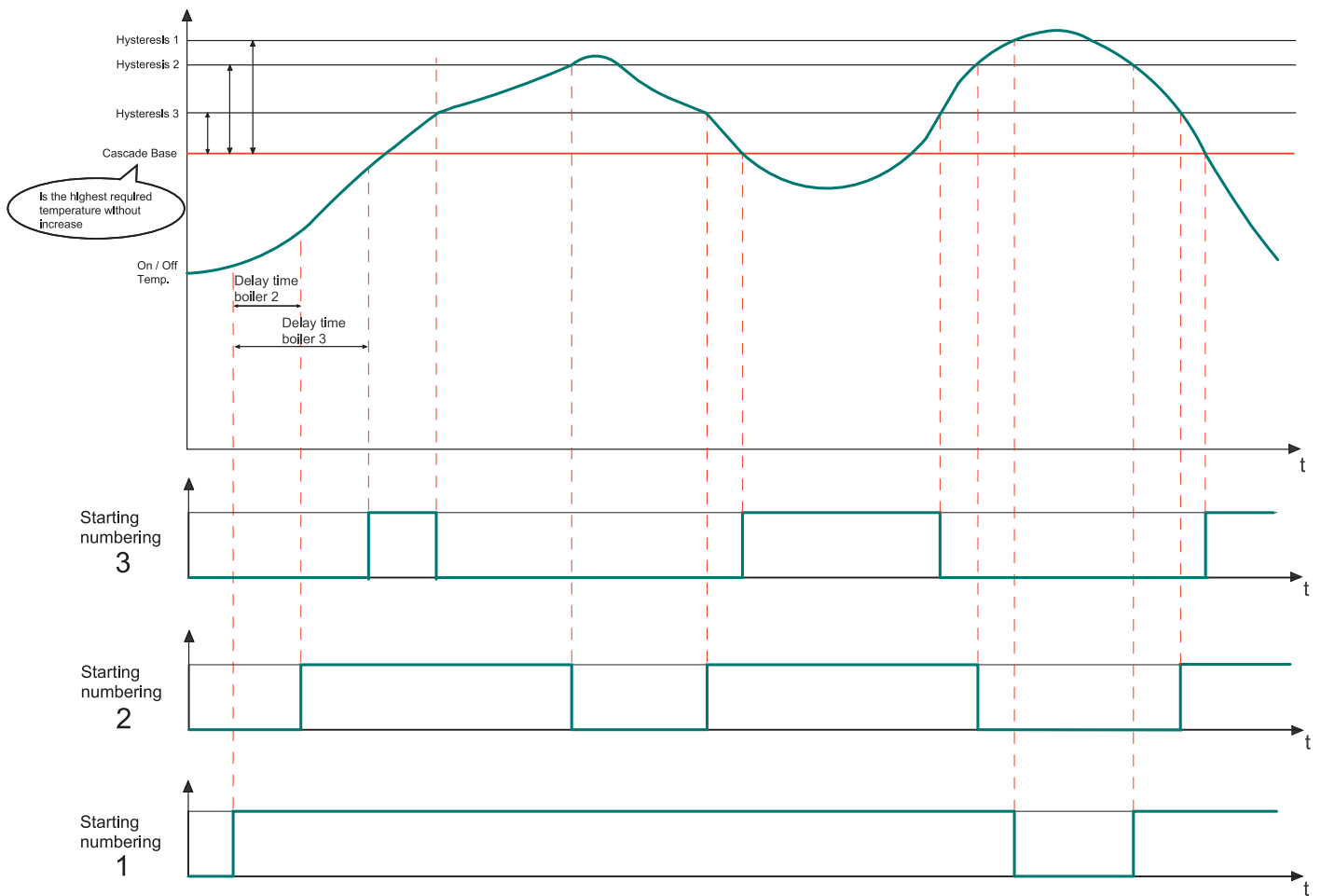

Back to the menu **Sys Regulation**.

13.13.2 Existing Boiler

In the menu **existing boiler** you can adjust the settings, when the system is operated with a pellet boiler and a further existing boiler.

If an existing boiler is available in the system, the heating controller identifies it by the boiler sensor of the existing boiler (terminal X13).

Additional terminals on heating controller:

- Terminal X13 – Boiler sensor Existing Boiler
- Terminal X24 – Switch valve



Note:

The Return flow increase of an existing boiler is not controlled by the controller.

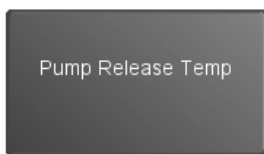

If the setpoint temperature on the boiler sensor of **existing boilers** (terminal X13) is exceeded, depending on allocation accumulator pump or heating circuit pumps get activated. Additionally the potential-free contact X24 (diverter valve) is switched.

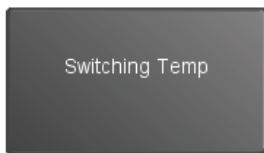

If the **Switch Temp** is reached, the Pellematic switches off. The switch valve stays to use the residual heat of the Pellematic.

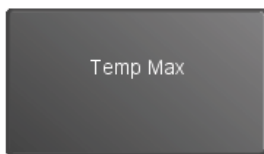

If the existing boiler reaches the **Temperatur Max** outside the heating times, all DHW circuits and heating circuits switch ON. (DHW preference is active).

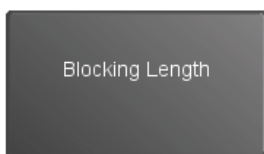

If the temperature of the existing boiler falls below the **Switch Temp** no burner demand is required within the delay time.



The inversion of the Switch Valve turns the reserve output of the first I/O Box. An installation of the Switch Valve in both directions is possible.

The following diagram shows exemplarily the mode of action and the dependence of the parameters

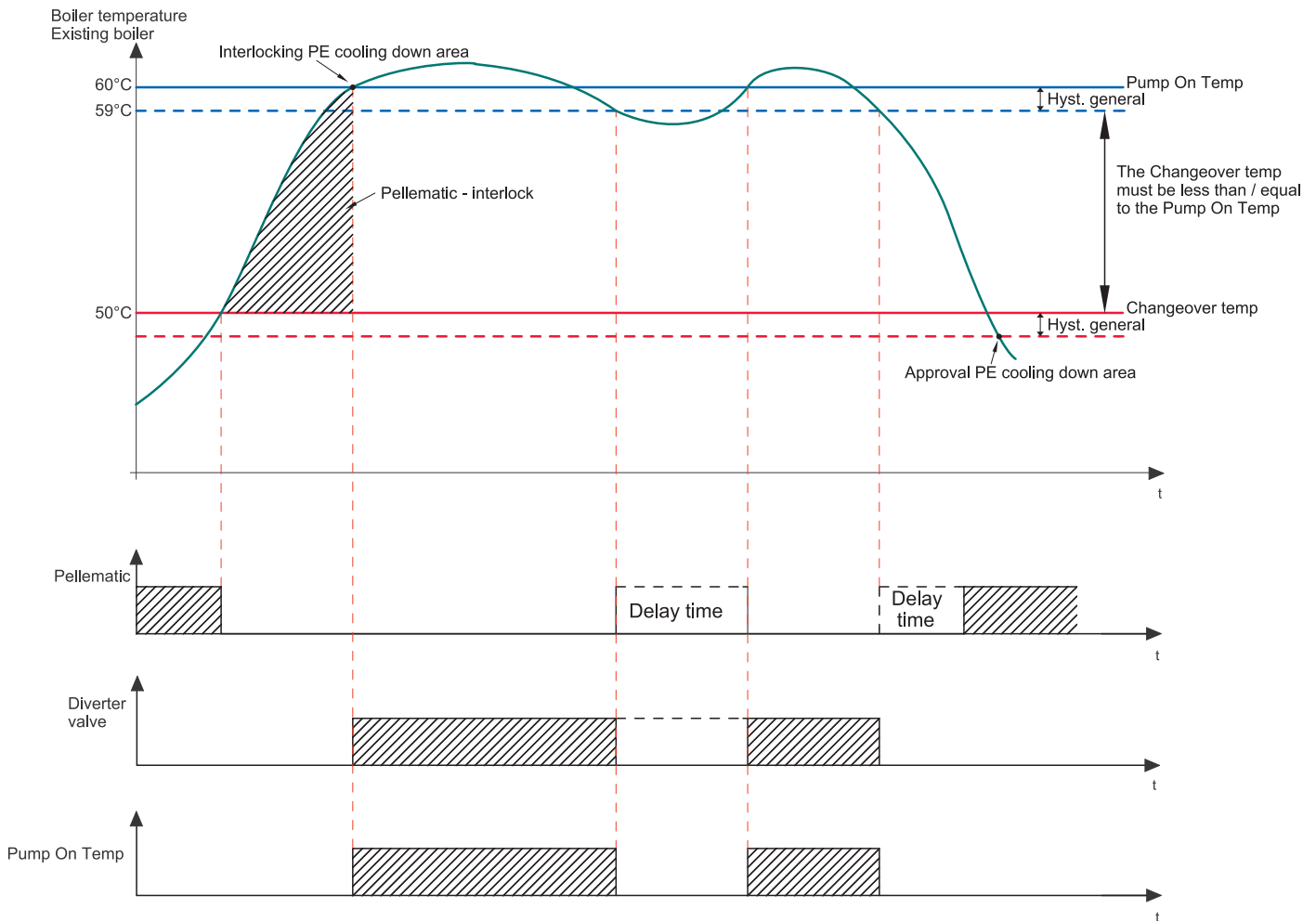

If the **Existing Boiler** reaches the **Switch Temp**, the Pellematic switches off. The system draws the energy further from the Pellet boiler, until the **Existing Boiler** reaches the Pump On Temp. Only then the energy from the **Existing Boiler** is obtained.

Advantages:

- The available energy of the Pellematic is used as much as possible.
- The condensation of the Existing Boiler is prevented.

Note:

The menu item **existing boiler** is only visible, if X 13 (S 2) is activated.



Back to **Sys Regulation**.

13.14 Pellematic settings



The menu item Pellematic settings contains the adjustments of the boiler controller.

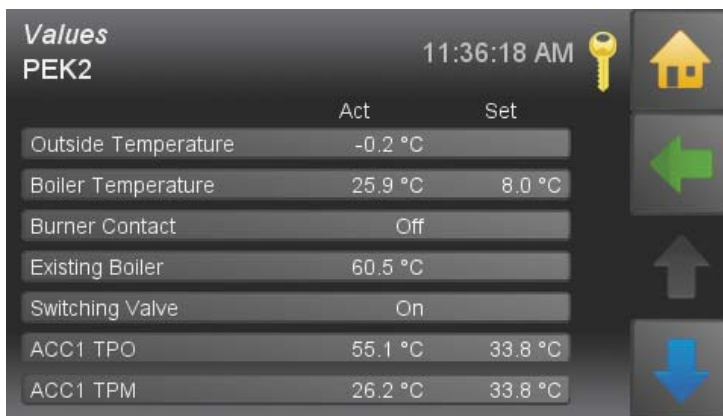

In this menu, no settings can be made. Values and settings (assignments) are displayed.

- actual values
- set values
- inputs (sensors)
- outputs (pumps, mixers and motors)

13.14.1 Outertemperature control

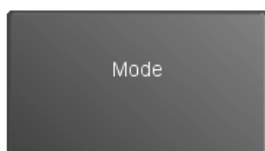

- On:** Set temperature minus 1 ° C
Off: Set temperature minus 1 ½°C

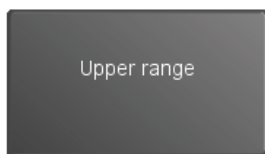

Boiler set temperature is according to the Upper range and Lower range increased or reduced.
 If outside temperature rises above the Upper range, the smallest boiler set temperature (set controller temperature) is used.

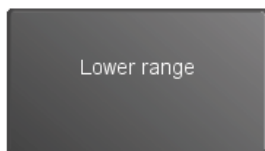

If outside temperature falls below Lower range, the biggest boiler set temperature (90°C) is used.

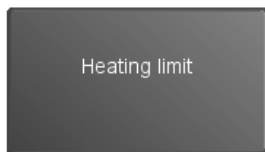

If outside temperature is above the set **Heating limit**, the boiler will not start – burner demand is blocked



Back to menu Pellematic

13.14.2 External Power Ventilator



Note: **External Power Ventilator** is only displayed, if USA — Mode is set to ON in Periphery learning.

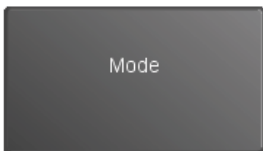

On: If mode is set to ON, external power ventilator starts at the set delay.
Off: If mode is set to OFF, external power ventilator is inactive.

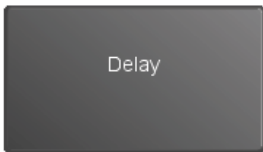

Here, the delay is set (1 - 32 sec).



Back to the menu **Pellematic**

13.14.3 Permanent operation



If you confirm the request, you activate the function **Permanent operation**. First of all, the spring-driven motor opens the fire protection system at the burner- the process takes about 2 minutes. After that the burner motor runs in permanent operation and transports pellets to the burner plate. In heating systems with auger delivery systems runs also the extraction auger in permanent operation.

If you confirm the request, you activate the **Permanent Operation**.

13.14.4 Ignition settings

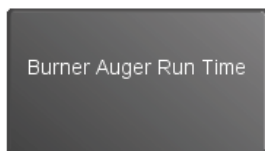

Run duration of the burner auger during the ignition period, expressed in tenths seconds.

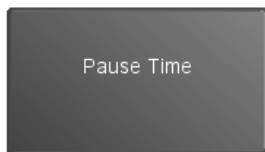

Rest Time of the burner auger during the ignition period, expressed in tenths seconds.

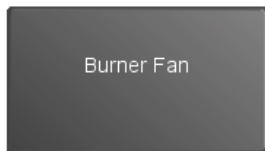

Speed of the combustion air fan during the ignition period.

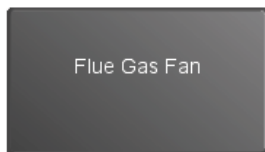

Speed of the flue gas fan during the ignition period.

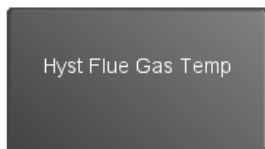

For a succesful ignition the flue gas temp has to be higher than the **boiler temp** plus **hyst flue gas temp**.

Note:

Display only if flue gas sensor is connected.

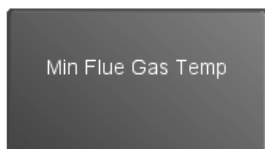

Flue gas min temp for the regulation of the boiler performance. If temperature falls below **Flue gas min temp**, the boiler rises its performance independent from the boiler temp.

Note:

Only displayed if flue gas sensor is connected.

On ignition the flue temp is investigated.

Ignition temp = **flue gas temp** plus **Hyseresis flue gas temp**.

If the calculated ignition temperature rises above the **max flue gas temp**, it is restricted to this **max flue gas temp**.

Note:

Only displayed if flue gas sensor is connected.

Softstart
Temp Hysteresis Softstart

If the **Combustion chamber temperature** falls by the adjusted hysteresis during the softstart, the boiler changes into **heating at full power**.

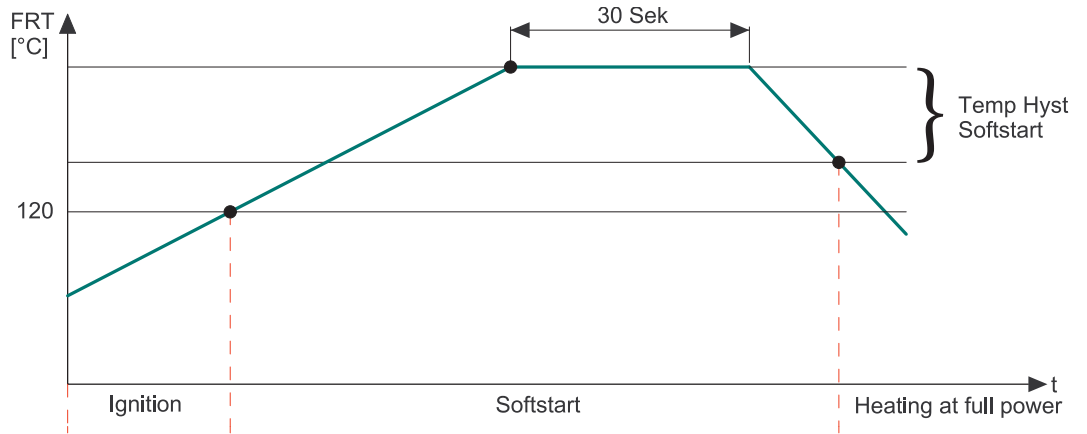

Back to the menu **Pellematic**.

13.14.5 Full power settings



Fuel Adjustment

The run duration of the burner auger is calculated from the boiler controller in dependence of the rated power and the boiler set temperature automatically. Accordingly, the burner motor is controlled. You can raise or reduce the run time, calculated by the boiler controller, respective in 10 steps.

Air Flow Rate++

Adjusting the speed of the combustion air fan in the Full Power mode.

Flue Gas Fan++

Adjustment of the speed of the flue gas fan in heating at full power (only when negative draft regulation is deactivated).

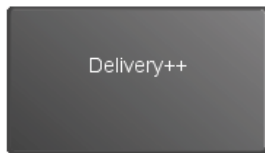

Adjustment of delivery at full power.
Only displayed if no combustion chamber sensor is connected.

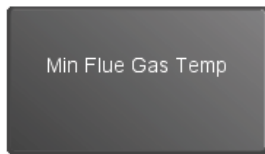

Exhaust minimum temperature for the control of the boiler performance.
If temperature falls below exhaust minimum temperature, the boiler increases performance regardless of the boiler temperature.
Only displayed if flue gas sensor is connected.



Back to the menu **Pellematic**.

13.14.6 Run Down Time settings

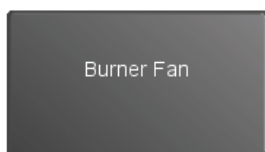

Adjusting the speed of the burner fan in the full power mode in percent. The speed reduces continuously in the run on time.

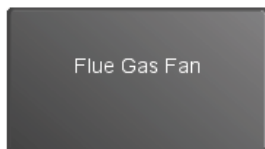

Adjusting the speed of the flue gas fan in the full power mode in percent. The speed reduces continuously in the run on time.

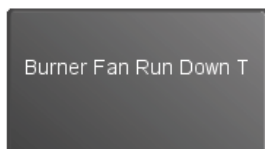

Minimum run on time of the burner air fan at the moment of switch off in seconds.

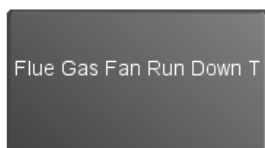

Minimum run on time of the flue gas fan at the moment of switch off in seconds.

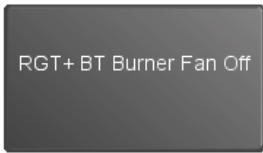

The burner fan runs after the minimum delay time has elapsed even until the flue gas temperature is lower than the boiler temperature + the set temperature value:

e.g: Boiler temperature = 76°C + 32°C = 108°C Switch off temperature.



The flue gas fan runs after the minimum delay time until the flue gas temperature is lower than the boiler temperature + the set temperature value:

e.g: Boiler temperature = 76°C + 12°C = 88°C Switch off temperature.

Note:

Display only if flue gas sensor is connected.

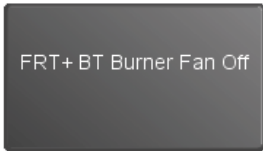

The burner fan runs after the minimum delay time until the combustion chamber temperature is lower than the boiler temperature + the set temperature value:

e.g: Boiler temperature = 76°C + 250°C = 326°C Switch off temperature.

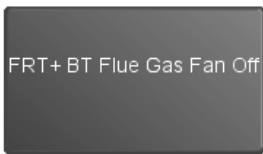

The flue gas fan runs after the minimum delay time until the combustion chamber temperature is lower than the boiler temperature + the set temperature value:

e.g: Boiler temperature = 76°C + 150°C = 226°C Switch off temperature.



Back to the menu **Pellematic**.

13.14.7 De-ashing system settings

The de-ashing system is fully automatic. A dedicated motor in the sub-assembly of the de-ashing system drives the de-ashing auger. Its function is controlled and tested by the boiler controller.

The motor in the sub-assembly of the de-ashing system drives the de-ashing auger and the turnstile agitator arm. The agitator arm conveys the ash to the de-ashing auger. The de-ashing auger conveys the ash from the ash chamber into the ash box.

When the ashbox is full then the alarm text **"Ash"** appears on the display of the control unit. If you do not empty the ash box, the completes a futher 3 de-ashing sequences before failing. The control unit then displays the alarm text **"Ash box full"**. The heating system switches off. The heating system switches back on again automatically after the ash box has been emptied.

For pellets with a very high ash content, it is necessary to extend the duration of the de-ashing process and possibly also extend the time interval between de-ashing processes.



The menu item **Ash Clean** is present after the activation of a external de-ashing system or an burner plate cleaning system. The activation is only possible after entering the Code for service technicians. The external de-ashing system and the burner plate cleaning system run parallel.

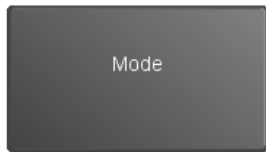

- Off** function de-ashing is deactivated.
- Ashbox** available ashbox + if necessary a burner plate cleaning system
- Burner** available burner plate cleaning system (without ashbox)

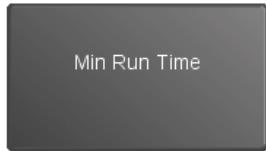

is the Minimum Run Time of the boiler until the next ash removal sequence. Value adjustable.

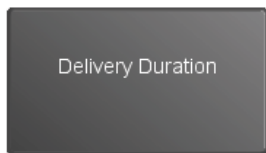

is the run time of the ash auger. Value adjustable.

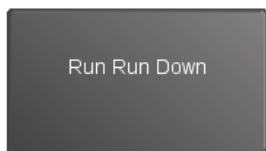

Remaining Run Time of the boiler after the error message "ash box full" until switches off completely.



Back to the menu **Pellematic**.

13.14.8 Boiler cleaning



Cleaning / Filling

The value to be set is the time (full hour) at which the boiler cleaning sequence is performed. On vacuum systems the hopper is also filled at the same time, regardless of whether it is empty or not.

Cleaning

You can set in **Cleaning/Filling** a second cleaning sequence. The value to be set is the time (full hour) at which the additional boiler cleaning sequence is performed. Example: 20h = additional boiler cleaning sequence performed at 20:00. On vacuum systems the hopper is also filled at the same time, regardless of whether it is empty or not.

Default value -1h: It is not performed a second cleaning sequence.

Min Run Time

Min Run Time of the boiler until next cleaning sequence. Value adjustable.

Cleaning Time

Duration of the boiler cleaning sequence in seconds. Value adjustable.



Back to the menu **Pellematic**.

13.14.9 Negative Draft

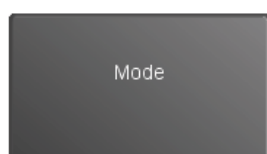

Activating the **negative draft regulation** is only possible when the negative draft measuring is closed.

On negative draft regulation active

Off negative draft regulation inactive

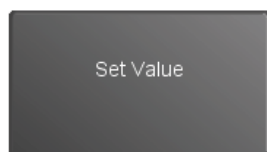

If the negative draft in the combustion chamber falls under the **Set Value**, the speed of the flue gas fan increases. Increases the negative draft, the speed of the flue gas fan reduces again. Value = 0, the negative draft control is inactive. (Displayed only with connected negative draft measuring)



If the negative pressure in the combustion chamber is below longer than the adjusted error time, the system shows the malfunction „Flue gas fan“

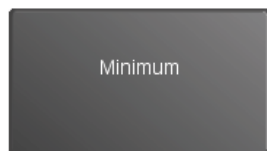

If the negative draft **Minimum** in the combustion chamber is below longer than 1 minute, the system goes into Malfunction. Value = 0 the Negative Draft control is inactive. (Displayed only with connected Negative Draft measuring)

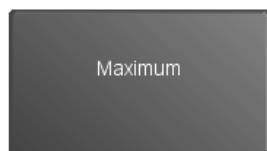

If the negative draft **Maximum** in the combustion chamber longer than 1 minute is exceeded, the system goes into Malfunction. (Displayed only with connected Negative Draft measuring)

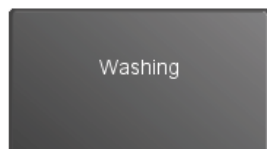

The function **Washing** is only available at condensing boiler systems. If the in **Washing** adjusted Negative Draft falls below, the scrubber cleans the heat exchanger of the condensing boiler. The washing occurs to the opposed washing duration and the washing interval, though maximum 1x per hour.

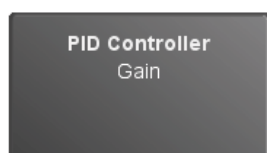

P-contingent for the regulation of the combustion chamber (Displayed only with activated negative draft control)



I-contingent for the regulation of the combustion chamber (Displayed only with activated negative draft control)



D-contingent for the regulation of the combustion chamber (Displayed only with activated negative draft control)



Back to the menu **Pellematic**.

13.14.10 FRT Controller



Activation of the combustion chamber temp is possible only if the combustion chamber temp sensor is active.

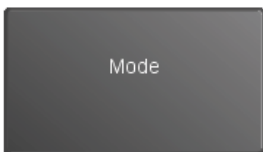

- On** FRT Controller active
- Off** FRT Controller inactive

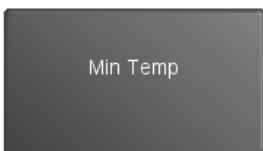

Is the combustion chamber minimum temperature for a successful ignition.

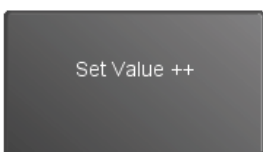

Set Value ++ for the regulation of the combustion chamber temperature.

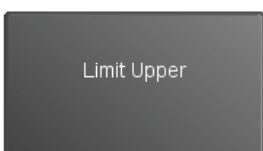

If the combustion chamber temperature falls below the **Set Value ++**, the run time of the burner auger increases maximum of this percentage.

Limit Lower

If the combustion chamber temperature raises above the **Set Value ++**, the run time of the burner auger decreases maximum of this percentage.

PID Controller
Gain

P-contingent for the regulation of the combustion chamber temperature.

PID Controller
Integration Time

I-contingent for the regulation of the combustion chamber temperature.

PID Controller
Different Time

D-contingent for the regulation of the combustion chamber temperature.



Back to the menu **Pellematic**.

13.14.11 Level detection system

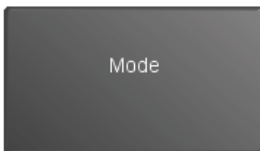
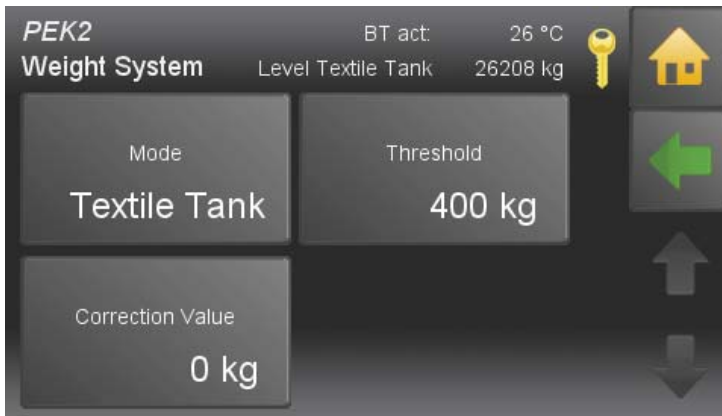

Selection options:

Off Function level detection system inactive.

Textile tank Level detection system of textile tank by weighting cells.

Storage room Put in the filling quantity after a pellet delivery. Level detection by weighting system of hopper. Only possible with Pelletboilers of the type PES 36-56.

Cap sensor Filling level detection in textile tank or storage room by capacitive sensor.

Insert filling amount after filling the storage room.

Note:

Displayed only if mode is set on **Storage room**.



The threshold value, **Minimum weight** for a warning message, is adjustable. The warning message appears on the operating device and will be terminated when filling level rises above the adjusted Minimum weight.

Note:

Only displayed if mode is set on **Storage room** or **Textile tank**

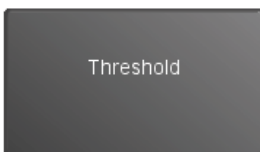

Set the display of the current weight to 0 by putting in the negative of the current weight shown.

Note:

Displayed only if mode is set on **Storage room** or **Textile tank**.

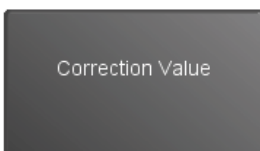

Back to the menu **Pellematic**.

13.14.12 Boiler Controlled Pump



Note:

The output Boiler controlled Pump (UW) is limited to 2.5A.

On Temp

When reaching the **On Temp** the output UW is activated or switched on the Boiler Controlled Pump. The On Temp is the boiler temperature minimum.

Depends on Require

When reaching the **On Temp** and a existence of a **Depends On Require** the output UW is activated. (The burner run on time is considered)
(Die Brenner-Nachlaufzeit wird berücksichtigt)

Pumptype

The menu **Pumptype** contains the following entries:

Asynchronus: Asynchronus pump – direct output 230VAC on/off

Async.Regulated: Asynchronus pump – pulsed output 230VAC

Heating Efficient: PWM1 - PWM signal inverted

Solar Efficient: PWM2 - PWM direct signal

Note:

When using an A-class pump as a **accumulator pump**, the pump can not be regulated from solar circuit 2.

NOTICE

Material damage by choosing the wrong pump type.

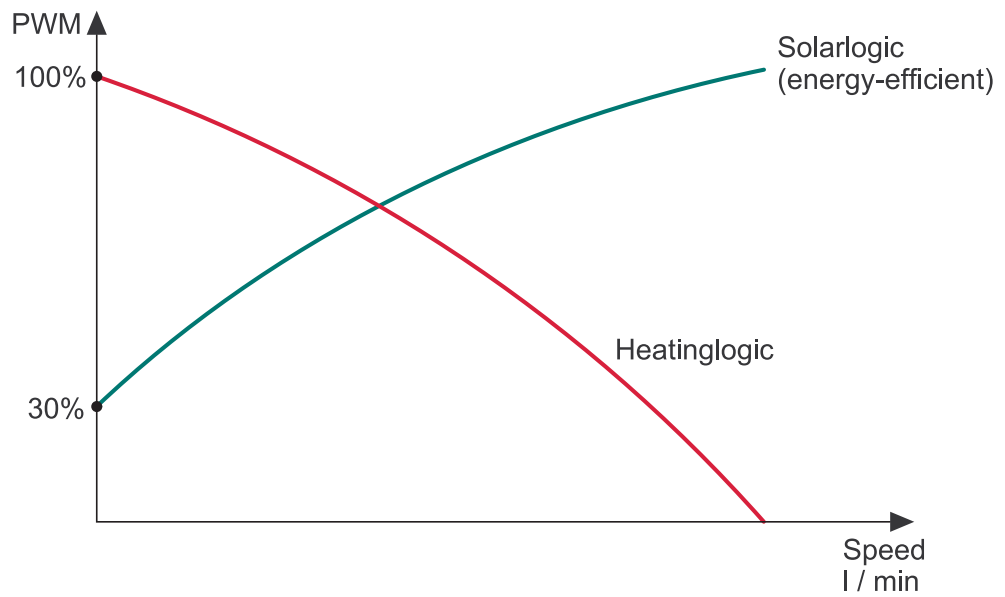

Switch Off Hyst

The **Switch Off Hyst** is the hysteresis for the boiler temperature minimum. It prevents the clocking (ON OFF ON OFF) of the Boiler Controlled Pump.

Run Down Time

The **Run on time** is the time how long the UW continues to run after the end of burner demand. – in minutes

Control Range

Is the **Control Range** of output UW at cycling mode. The speed controller starts at the boiler temperature minimum with a speed of 30% and increases to the boiler temperature minimum + **Control Range** up to 100% speed.



Back to the menu **Pellematic**.

13.14.13 Suction turbine



Note:

The menu item **Suction turbine** is only visible in suction systems.

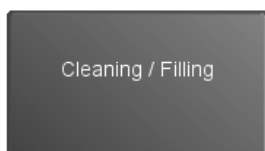

Set a Time (full hours), at which the hopper gets refilled, regardless how full it is at this time.
At the same time the purification of the boiler will take place.
This adjustment matches Cleaning/Filling.

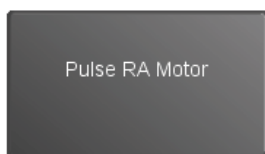

Frequency for storage room suction systems in pulse mode, only for vacuum systems.

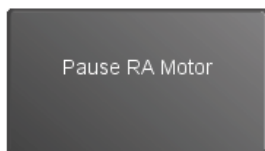

Pause time for storage room extractor motor - suction system in pulse mode. If pause time = 0 then no pulse mode.

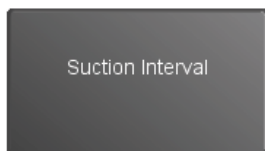

Run time of burner auger until next Suction Interval.
The hopper is filled at this time regardless whether it is empty or not.

- 175 min = 12 - 20 kW
- 225 min = 25 - 32 kW
- 90 min = 36 - 56 kW



Back to the menu **Pellematic**.

13.14.14 Output Settings



Output Settings has following menu items:

- Ignition Stick
- Ash Clean
- Magnet Valve
- Boiler Clean
- Flue Gas Fan
- Boiler Control Pump
- Delivery System
- Burner Auger
- Burner Fan
- Fire Protection

Display of all **Output Settings** in the system. Allows remote verification of pumps and valve settings.
 Exception: Accumulator pump – controlled by the boiler
 For each connected motor, you will see the following values: mA-actual, volt-actual, mA-minimum-set, mA-maximum-set, operating hours, Length of time in which the motor shall be located beyond of the min and max values before an error message is displayed.
 The min. and max. values and the duration are adjustable.



Back to the menu **Pellematic**.

13.14.15 Output Test



The Output Test serves to check all connected outputs:

- all motors
- relay fault signals
- magnet valves
- boiler controlled pumps

Note:

After choosing of one port, the operation will be interrupted.

By leaving the menu **output test** the normal operation will continue.

The output test is designed to test all outputs connected to the system (e.g. all motors, the alarm signal relay, the solenoid valve and the recirculation pump).

By using the operative device and typing in the code, you can access the item **output test** in the menu **general**.

You can control the required output with ON / OFF and choose the power input 0 -100%.

Designation	Check if	If not, then check
Motor suction fan VAK	the suction fan on the hopper is running	<ul style="list-style-type: none"> • the suction fan is connected • the fuse is defective • the motor is defective
Ignition ZUEND	the electrode is working: you can view the current draw at the control unit after it has been switched on.	<ul style="list-style-type: none"> • the wiring is correct • Check the ignition electrode
Motor ash auger AV (optional)	the motor ash auger is running	<ul style="list-style-type: none"> • the de-ashing system is switched on • the ash box is properly located and locked in position • the ash box is correctly wired up
Solenoid valve MA	the solenoid valve switches over and you can hear it click Note: Low temperature systems only	<ul style="list-style-type: none"> • the scrubber is connected • the scrubber is defective
Cleaning motor RM	the cleaning motor raises and releases the cleaning springs	<ul style="list-style-type: none"> • the terminal bolts on the shaft are tight • the motor is defective
Fault signal relay SM	the relay switches on and off: you can hear it clicking on and off	<ul style="list-style-type: none"> • the wiring is correct • the fault signal relay is defective
Flue gas fan SZ	the flue gas fan is running	<ul style="list-style-type: none"> • the wiring is correct • the motor is defective
Boiler controlled pump UW	the boiler controlled pump is running	<ul style="list-style-type: none"> • the wiring is correct • the boiler controlled pump is defective

Designation	Check if	If not, then check
	<p>Note: only possible if the boiler controlled pump is connected</p>	
Motor store room auger RA	<p>the motor auger store room is running</p> <p>Note: On suction systems, switch on the suction fan motor first otherwise the motor on the store room auger may become jammed.</p>	<ul style="list-style-type: none"> the store room auger motor is connected the auger rotates easily the motor is defective
Motor hopper RES 1	<p>Note: PES 36–56 only</p>	<ul style="list-style-type: none"> the wiring is correct the motor is defective
Motor burner auger ES	<ul style="list-style-type: none"> the motor that feeds pellets to the burner is running auger is correct. the direction of rotation of the store room auger is correct 	<ul style="list-style-type: none"> the burner auger motor is connected the burner auger motor rotates easily the motor is defective
Combustion air fan LUFT	The combustion air fan is running	<ul style="list-style-type: none"> the wiring is correct the motor is defective
Anti-blowback system BSK	the fire protection flap (orange motor on burner) opens	<ul style="list-style-type: none"> the wiring is correct the ball valve moves easily the motor is defective
Scrubber pump	<p>Note: not implemented at this type of boiler</p>	<ul style="list-style-type: none"> the wiring is correct the scrubber pump is defective

13.14.16 Maintenance

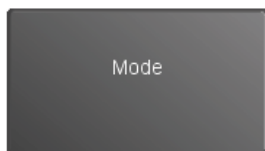

Off No Maintenance reminder

On Function Maintenance reminder active.
After reaching the maintenance interval a message is displayed and an e-mail is sent.

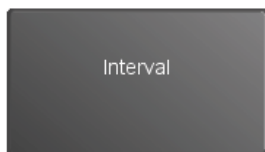

The maintenance interval is adjustable from 1 to 24 months.

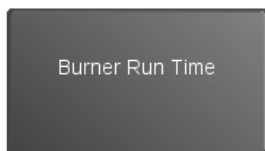

After reaching the adjusted Burner run time, a Message is displayed and an e-mail is sent. Adjustable from 1 to 10000 h.

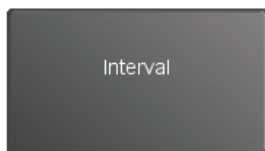

Off No Maintenance reminder

On Function Maintenance reminder Burner run time active.



If you accept the request, you activate the function **Burner run time clear**.
As a result, the enumerators of burnerstarts, Averaged Run Time, Down time and amount of ignitions will be set to 0 (see **Pellematic measuring values**).



Back to the menu **Pellematic**.

13.14.17 Calibrate



After activating the function **calibrate**, the boiler gets a burner request.

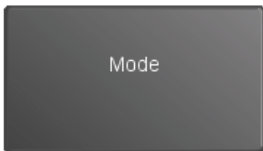

- Off** Function Calibrate inactive.
- On** Function Calibrate active.

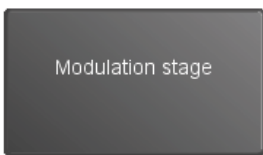

Actual modulation level of the boiler.
You can adjust the modulation level (level 1 - 17) for measuring flue gas.

- Level 1:** min. performance of boiler (30%)
- Level 17:** max. performance of boiler (100%)

Note:

The adjusted modulation level will be kept until the end of the calibration time. But meanwhile the calibration time, adjustments of the modulation level are possible.

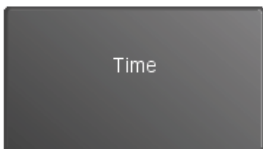

Max. Duration of the flue gas measuring (1 - 90 min).
After Rundown of the adjusted **calibration time**, calibration will end.



Back to the menu **Pellematic**.

13.14.18 Magnet Valve



Note:

The menu Item **magnet valve** is only available, if your system includes a condensing execution technologie after periphery learning.

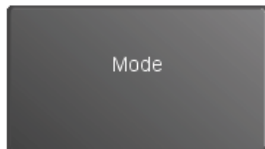

Mode

Activate the washing function (ON/OFF)

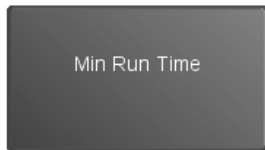

Min Run Time

Minimum Run Time of the boiler until the next cleaning.



Washing Time

Duration of boiler cleaning in seconds.



Back to the menu **Pellematic**.

13.14.19 Settings

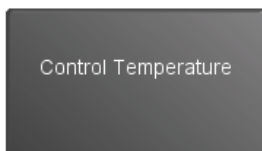

Setting of the **boiler setpoint temp.**

Note:

If heating controller demands a higher temp than the adjusted **regulation temp**, the heating controller sets the regulation temp. The **switch off temp** will be raised parallel to the regulation temp.

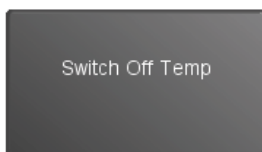

Reaching the Switch Off Temp, the boiler switches off.

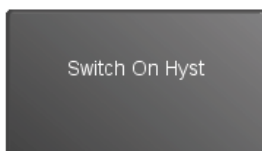

In case the boiler temp drops under **switch off temp** minus **switch on hyst**, the boiler activates again (as long as a burner request exists).

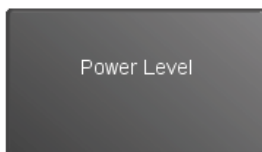

Adjusting the boiler performance is only possible inside the learned boiler size.

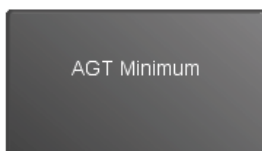

AGT Minimum is to regulate of the boiler performance.

If the Flue gas minimum temperature falls below, the boiler power increases independently of the boiler temperature, Displayed only with connected flue gas sensor.

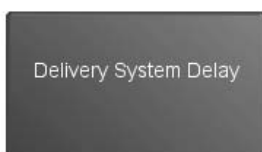

Delay of the Delivery System relative to the burner auger – only at auger systems.

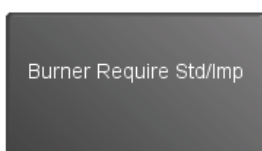

Choose between 2 types of regulating the burner:

Standard: Boiler runs in accordance with the burner demand of the heating controller.

Impuls: Boiler starts when the heating controller send a one-time impulse and switches off when the Switch Off Temperature is reached.

Malfunction Mode

If a malfunction occurs, the boiler controller controls the relay fault signal. The potential-free contact (Output SM 20 19) displays the malfunctions by using an external display device. (1-230V).
You can choose the following functions:

On / Off: By warning **Ash** or warning **Pellets** the contact closes.

1x: If a malfunction occurs, the contact closes – Closer
By warning "Ash box full" appears a flashing pulse. (Contact closes once)

blinc:

Depending on the error, the malfunction contact gets switched with different impulses.

Output SM

Choose between 2 ways of exits:

Standard: the exit is set when an error occurs.

Inverted: the exit is set back when an error occurs. (Contact SM is opened)

Hand Filling Hopper

Setting, if Pellematic is installed as a Hand filling hopper.
0 = inactive, 1 = active

Input AK

Choose between 2 ways of entries:

Standard: the boiler gets blocked, if contact AK is closed.

Inverted: the boiler gets blocked if contact AK is open.

Capacitive Sensor
RA Active

Activate the capacitive sensor on the burner.
0 = inactive

Capacitive Sensor
ZW Active

Activate the capacitive sensor on the hopper.
0 = inactive, 1 = active



Back to the menu **Pellematic**.

13.15 Heating Main Pump



If no return temperature sensor of the return pump is connected to the system, the Heating Main Pump appears automatically in the Main menu. Per heating controller there is max. one Heating Main Pump possible. You switch the Heating Main Pump ON and OFF. The Heating Main Pump is a backup pump. You assign the pump to all available pumps in the system. When you click on an icon, it lights up green. A green icon symbolizes an assigned pump.

Note:

A Heating Main Pump and a Return Pump exclude themselves.

13.16 General settings

General settings includes the whole heating control, all relevant settings and individual operation options for the customer.



Detailed information for the following sub menu items are in the manual for the End User.

- Chimney
- Favorit
- Local Settings
- Sensor Adjust
- Malfunction
- Information



More adjustments for the ÖkoFEN Service technician:



For long cable lengths are slight variations of the sensor values possible. The Sensor Adjustment function allows you to adjust each sensor by plus/ minus 10° C.

Note:

You have to connect each sensor to the heating controller and activate it in the menu item Periphery Learning.



Back to the menu **General**.

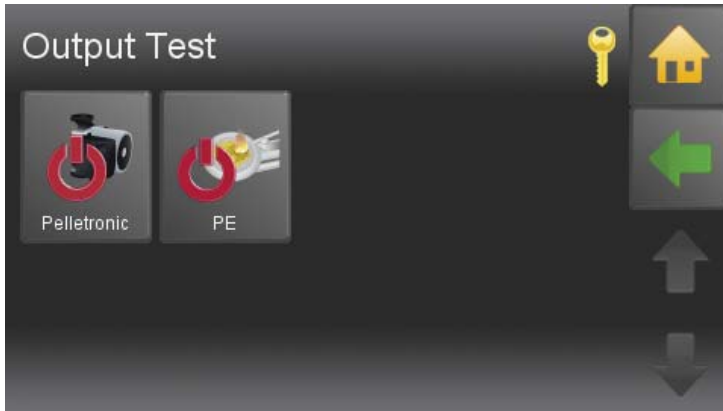

Output Test Pelletronic:

Here you find all the heating controller connected devices. You can switch each device on and off.

Output Test Pellematic:

Here you find all the boiler control connected devices. You can switch each device on and off.



Back to the menu **General**.

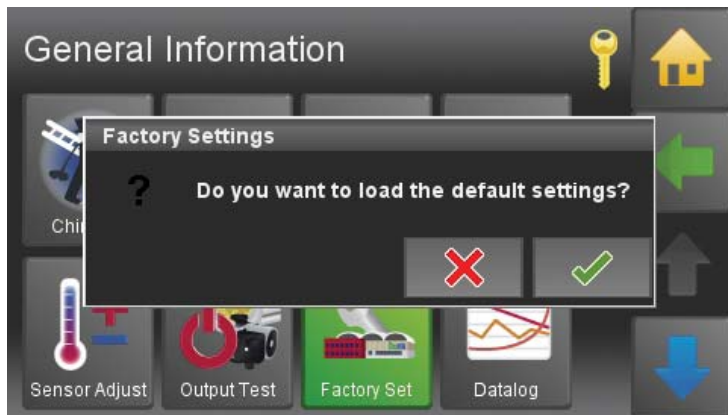

You can reset the original **factory settings**.

Note:

A loading of the factory settings clears the bus address and restarts the system.



Back to the menu **General**.

13.16.1 Chimney

The function chimney is only for chimney draughts and authorized service technicians. It is used for the measurement of exhaust gas.



The menu item **Chimney** is situated in the menu General.



Please choose the function **Chimney**.

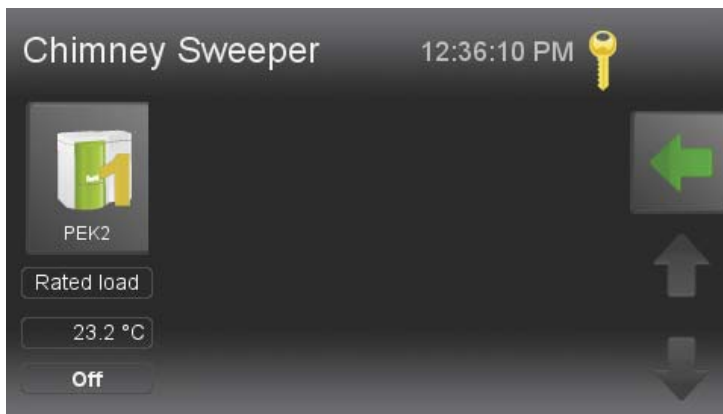

For every boiler in the system, it is possible to run a nominal load or partial load measurement.

Note:

This menu only shows if a cascade exists in your system.



- The boiler temperature is set to 60°C for a total runtime of 30 minutes.
- You also can see actual boiler temperature and the rest of the time limit.
- After the expiry of the time limit the function chimney ends. time of expiry the operation Chimney sweeper ends.
- The button Cancel ends the function Chimney.

13.16.2 Datalog

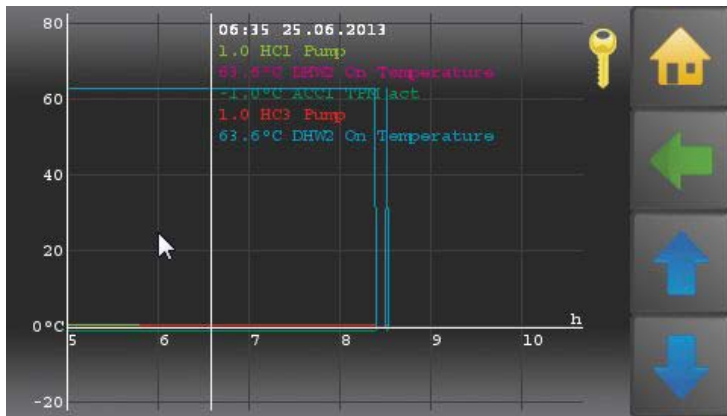

In Datalog logging data can be evaluated.

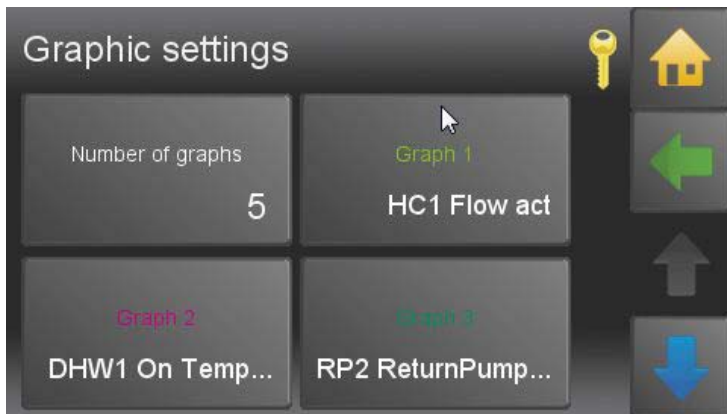

Select graphics by clicking in the area left of the Y-axis. Choose the number of graphs and the values you'd like to display. This graph can be accessed also online (logging data).

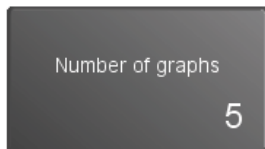

Determine the number of displayed graphs (1 - 12).



Back to the menu **General**.

13.16.3 Delete Log



With a click on **DeleteLog** data from the data log can be deleted.

Confirm the warning message with . Then the operating device restarts.



Back to the menu **General**.

13.16.4 ModBUS

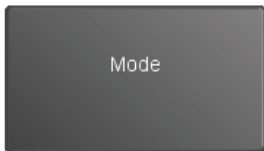
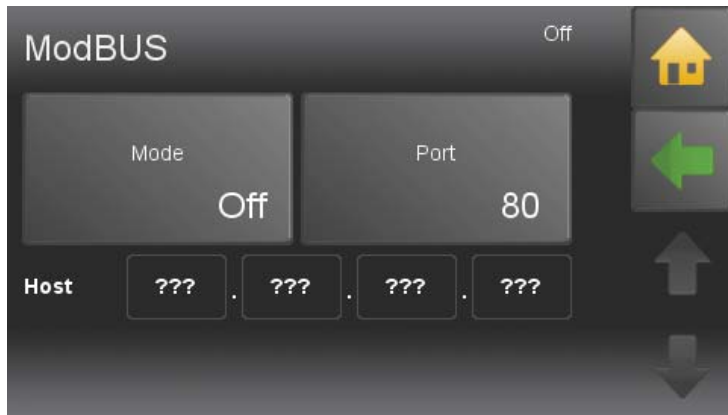

Off
TCP Server

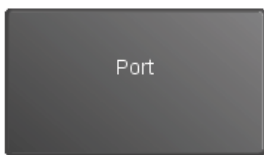

Defaultport for ModBUS is 502.

ModBUS Variables:

Variable	Register	Description
TEMP	2	Current cascade set temperature
TEMP_NEW	3	New cascade set temperature
TEMP_SET	4	If 1 the new cascade set temperature is adopted
FA_COUNT	5	Amount of boiler
PU_COUNT	6	Amount of accumulator
FEHLER CODE 1	10	First 4 digits errorcode, last digit user number (starts with 0) e.g.: 50060 (sensor fracture boiler 0)
FEHLER CODE 2	11	
FEHLER CODE 3	12	
FEHLER CODE 4	1	
FEHLER CODE 5	14	
FA1_MODE	20	Boiler Mode 0=Off 1=Auto 2=On
FA1_MODE_NEW	21	New Mode
FA1_MODE_SET	22	If 1 the new mode is adopted
FA1_TEMP	23	Current boiler temperature
FA1_TEMP_NEW	24	New boiler temperature

FA1_SET_TEMP	25	If 1 the new boiler set temperature is adopted
FA1_STATE	26	Boilerstate
FA2_MODE	30	
....		
FA3_MODE	40	
.....		
FA4_MODE	50	
FA4_MODE_NEW	51	
FA4_MODE_SET	52	
FA4_TEMP	53	
FA4_TEMP_NEW	54	
FA4_SET_TEMP	55	
FA4_STATE	56	
FA4_ERROR	57	
PU1_TPO	60	current AC upper temp
PU1_TPM	61	current AC middle temp
PU1_MIN_ON	62	If AC temp falls below this temperature, it is heated until MIN_OFF temperature
PU1_MIN_ON_NEW	63	new MIN ON temperature
PU1_MIN_ON_SET	64	If 1 the new temperature is adopted
PU1_MIN_OFF	65	Accumulator is heated until this temperature
PU1_MIN_OFF_NEW	66	new MIN OFF temperature
PU1_MIN_OFF_SET	67	If 1 the new temperature is adopted
PU2_TPO	70	
PU3_TPO	80	
PU3_TPM	81	
PU3_MIN_ON	82	
PU3_MIN_ON_NEW	83	
PU3_MIN_ON_SET	84	
PU3_MIN_OFF	85	
PU3_MIN_OFF_NEW	76	
PU3_MIN_OFF_SET	77	



Back to the menu **General**.

13.16.5 E-Mail

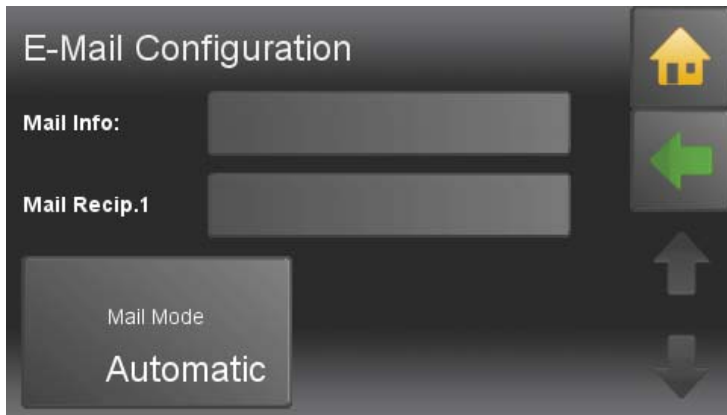

Delivery of disturbance-emails is done through an ÖkoFEN server.

Only the recipient address needs to be configured.

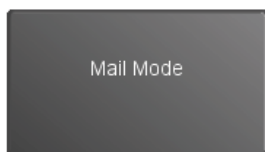

Mail Mode

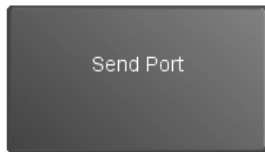

Send Port



Security

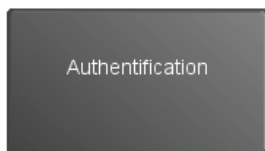

Authentication

To ensure maximal flexibility, E-mail settings can set individually.



Back to the menu **General**.

13.16.6 IP Config



Please choose the submenu item **IP Config** in the menu General.

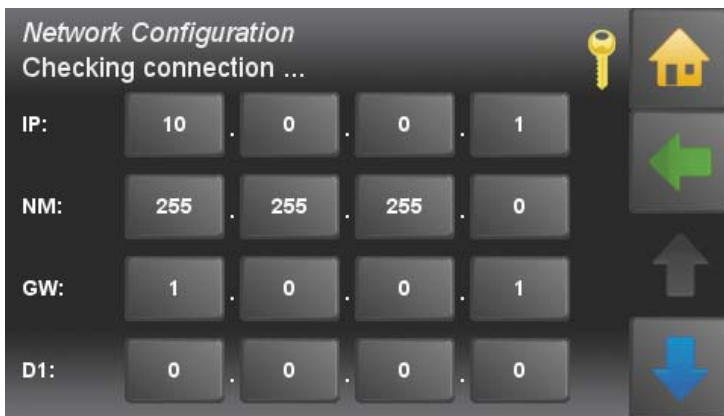

Insert the **IP (Adress)**, **NM (Netmask)** and **GW (Gateway)**, D1 (in most cases similar to GW) and **D2 (optional)**.

IP: IP address in the local network

NM: Networkmask is required in the local network.

GW: The gateway enables the touch operating device the access to the internet.

D1, D2: Server, which provide routing information



Set **DHCP On** or **Off** depending on your network.

Enter the **Port** (Default **80**).

Web: IP address in local network

Web User: Networkmask is required in local network

Web Password: The gateway enables the touch operating device the access to the internet.



Activate optionally the **Ping** function.

NOTICE

To prevent the modem from switching into standby mode, a ping command is executed every 10 minutes.

You get the data from your network technician.

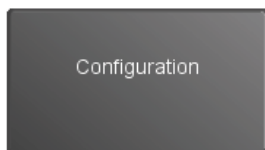

This menu item is only active when a compatible USB wireless adapter is connected. (not every wireless stick works with the Touch operating device)
By default, this item is hidden and located in LAN mode.
If the wireless mode is enabled, a password box appears.

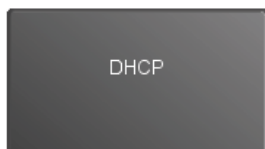

Dynamic address assignment on the local network (should be disabled if possible).



If a WLAN stick is recognized and supported, an Additional LAN & WLAN button appears.

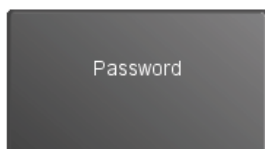

Password of router.

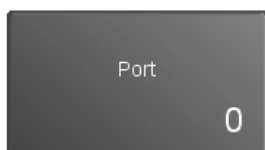

Address extension with which the touch remote control is accessible.
In principle, you can make your own choice, certain ports are associated with special services, e.g. 25 Mail, 80 Web and so on.

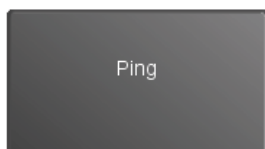

The ping prevents the internet connection from being closed by the router. Therefore a query to the ÖkoFEN server is started at certain time intervals. So the router detects that the connection is still active.

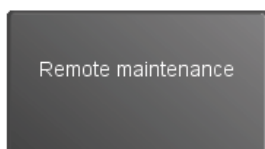

Automatic: This will attempt to automatically set up the router using the UPNP protocol port forwarding.
If this service is disabled on the router or doesn't work properly, it is canceled accompanied by an appropriate error message.
As this function is time-consuming (may take a few minutes), it is running in the background. Whatever the UPNP
If available, the Touch operating device registers on the ÖkoFEN remote control server with its current external IP Address.
In case of change of address by the external provider, this is detected and sent to the server Ökofen.

Manual: In this mode, the port forwarding must be set manually. (for lack of UPNP)

The port of the touch panel must correspond to the external shared port.
The touch then registers with the external IP address and port on ÖkoFEN remote maintenance server.
In case of change of address by the external provider, this is detected and sent to the ÖkoFEN server.

Static:

In this mode, no connection data is transferred to the ÖkoFEN server and the online service of ÖkoFEN can not be used.
But the remote control of the Touch operating device remains active and can be used as before via port forwarding, DynDns, fixed external IP, LAN and so on.

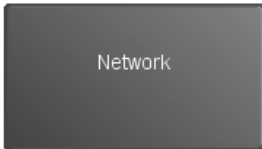

All functions for the network/internet can be disabled here.

Remote maintenance access

This function determines the network settings automatically.
For this the DHCP mode is activated and the required settings are set automatically.
Afterwards DHCP is deactivated.
Because of this, the IP address of the control unit can change.

The settings are set as follows:

- DHCP Off
- Ping On
- Port 8080
- Remote maintenance: Automatic



Back to the menu **General**.

13.16.7 USB

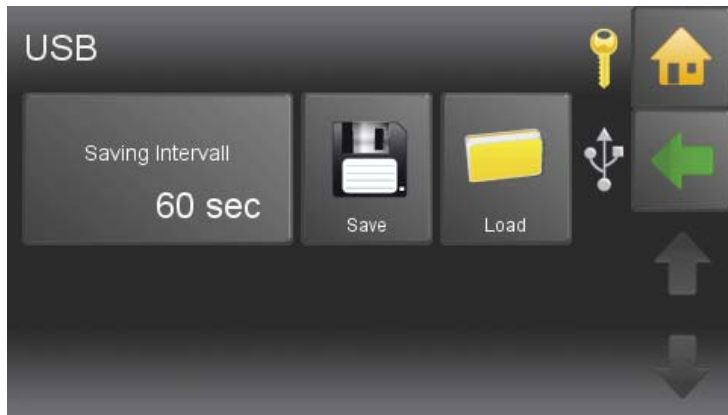

USB is used for recording data.

You must have plugged in USB stick.

If a USB-Stick is connected, data are recorded according to the set saving intervall.

Note:

If no USB-Stick is connected, the recorded data is saved on the internal memory (fixed intervall = 60 sec.).

Records that are older than 3 days are deleted from memory.

If a USB-Stick is connected (USB 0), the internal data records are copied additionally to the USB stick in the folder "Touch" (recording interval adjustable).

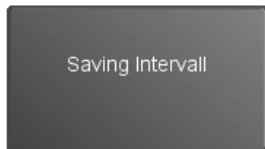

Set the Saving Intervall of the recording (5 - 60 sec.)



Is used to store individual settings on the inserted USB-Stick.

With the file name which you enter here, you can access the data when loading settings again.



Load the saved settings.



Back to the menu General.

13.17 Software settings



Software is in the Main menu.



13.17.1 Configuration

The Touch Controller is either MASTER (= Operating device) or SLAVE (= Remote control). The Touch controller is standard as **Master** configured. It must therefore be configured locally in accordance with the use.

Note:

Per Heating system it may only configured one Touch as Master (operating device) and one as slave (remote control).

Procedure:

1. Choose menu item Software **Touch Configuration**.
2. Choose for each Remote control the Configuration **Slave** and assign it to a **heating circuit**.
3. Wait until all participants are booted up and operated.
4. Learn Periphery
5. The Operating device and the associated Remote controller are functional now.

13.17.2 Function room sensor

The **room sensor** can only be activated:

- If a touch controll is configurated as master.
- If a touch controll is situated in the living area.

Activate the integrated room sensor by allocating the **room sensor** master to the heating circuit (HC 1-6).



Back to the **Main menu**.

13.17.3 Update Heating Controller, Touch Operating device and Remote Control

The update is for the heating controller, the Touch operating device and the Touch remote control

NOTICE

All adjusted settings of the heating controller and the boiler controller are deleted in case of a software update! Record your settings and parameters.

Note:

For updating all devices, only 1 software is needed.



This function is in the menu item **Software**.



Firmware Update – Approach:

1. Switch off the complete heating system.
2. Plug in the USB flash drive with the new software in the back of the slot: **USB 0** of the heating controller.

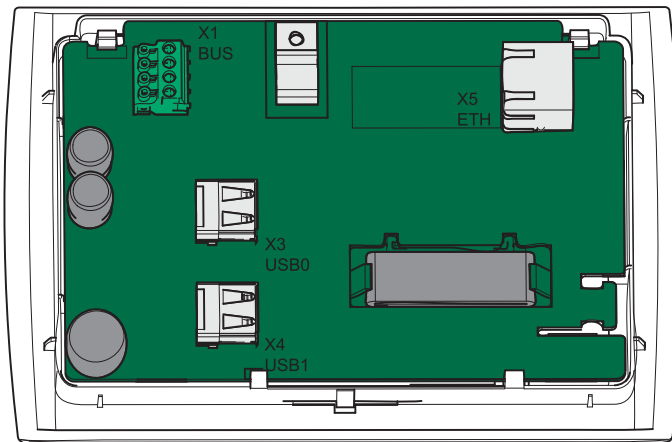
**Note:**

Use only suitable USB-sticks. (no wooden ÖkoFEN USB-sticks)

3. Place the touch operating device in the control panel.
4. Switch on the heating controller.
While booting up, software update of operating device starts automatically
Begin with the update of all Touch remote controls and operating devices.
5. Go to the **CODE** button, enter the code to reach the level settings.
6. Go to the button **Software**
7. Choose **Update** 

Note:

If you have forgotten to insert the USB stick - Press the **Refresh** button (wait about 1min)

8. All components can be selected at the same time.
9. Press the Button **Update** and reply to the query with **YES**.

After all components are updated, disconnect all from the power supply, reconnect and then restart them to produce the bus connection again.

13.17.4 Software Update

First perform a software download. In the ÖkoFEN download area is always the current software available for downloading.

Link: <http://ftp.pelletsheizung.at>

For access information, please contact your ÖkoFEN representation.

14 Appendix

14.1 Malfunctions

14.1.1 Malfunctions - what to do

Follow the sequence described for handling malfunctions.

- The heating system switches off automatically if a malfunction occurs.
- The control unit display shows a malfunction alarm text.
- You have to rectify the cause of the malfunction.
- After rectifying the malfunction, you have to reset the fault text by pressing  before starting the heating system again.

14.1.2 Fault texts

The fault text displayed on the screen provides information on the type, time and status of the malfunction as well as help for troubleshooting.

The menu item **malfunction** saves errors as long as they are not solved.
The chronological order of the errors helps to find the reason of the malfunction.

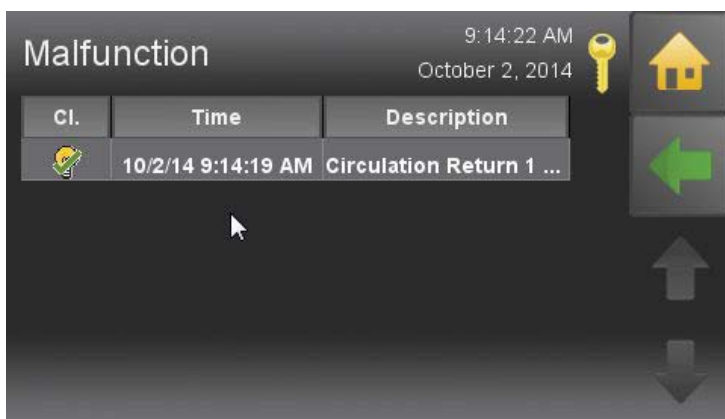

There are 3 different status of Malfunction messages

1. **C** – New fault: when the fault occurs
2. **G** – Rectified fault: when the fault has been rectified
3. **Q** – Reset fault: when the fault has been reset by pressing 

In the menu point **information**, all malfunctions are listed chronologically.



14.1.3 Malfunction report

This is a list of all malfunction reports on the display.

Code	Display	Input / Output		Affected element	Solution table		
1001	HC1 Flow BC	X4 or X5		Heating controller	13.1a		
1002	DHW1 OnSensor BC	X6					
1003	Outside Sensor BC	X2					
1004	Boiler Sensor BC	X3					
1008	TPO1 BC	X7					
1009	TPM1 BC	X8					
1010	Collektor1 BC	X15		Heating controller	13.2a		
1011	TPU1 BC	X9 or X10		Heating controller	13.1a		
1012	Flow Energy1 BS	X16					
1013	Return Energy1 BS	X17					
1014	ExistBoiler1 BS	X13					
1017	Cascade OnSensor BC	X3 or X7					
1018	Cascade OffSensor BC	X3 or X8					
1019	Circulation Return1 BC	X14					
1020	DHW1 Off Sensor BC	X6 or X7, X8, X9					
2001	HC1 Flow SC	X4 or X5				Heating controller	13.1b
2002	DHW1 OnSensor SC	X6					
2003	Outside Sensor SC	X2					
2004	Boiler Sensor SC	X3					
2008	TPO1 SC	X7					
2009	TPM1 SC	X8					
2010	Collektor1 SC	X15		Heating controller	13.2b		
2011	TPU1 SC	X9 or X10		Heating controller	13.1b		
2012	Flow Energy1 SC	X16					
2013	Return Energy 1 SC	X17					
2014	ExistBoiler1 SC	X13					
2017	Cascade OnSensor SC	X3 or X7					
2018	Sonde arrêt cascade CC	X3 or X8					
2019	Circulation Return1 SC	X14					
2020	DHW1 Off Sensor SC	X6 or X7, X8, X9					
3001	HC1 Flow	X4 or X5				Heating controller	13.1c
3002	DHW1 OnSensor	X6					
3003	Outside Sensor	X2					
3004	Boiler Sensor	X3					
3008	TPO1	X7					
3009	TPM1	X8					
3010	Collektor1	X11		Heating controller	13.2c		
3011	TPU1	X9 or X10		Heating controller	13.1c		

Code	Display	Input / Output		Affected element	Solution table
3012	Flow Energy1	X16			
3013	Return Energy1	X17			
3014	ExistBoiler1	X13			
3017	Cascade OnSensor	X3 or X7			
3018	Cascade OffSensor	X3 or X8			
3019	Circulation Return1	X14			
3020	DHW1 Off Sensor	X6 or X7, X8, X9			
4005	BUS HCR 1	X1A or X1B			
4006	BUS PE 1	X1A or X1B			
4007	BUS Remote 1	X1A or X1B			
4015	BUS Remote Touch 1	X1A or X1B			
4016	BUS Master	X1A or X1B			
4021	BUS Radio Remote 1	X1A or X1B			
5000	PE1 Reserve sensor1 BS	R1		Boiler Controller	13.1a
5001	PE1 Reserve sensor1 SC	R1		Boiler Controller	13.1b
5002	PE1 Reserve sensor2 BS	R2		Boiler Controller	13.1a
5003	PE1 Reserve sensor2 SC	R2		Boiler Controller	13.1b
5004	PE1 Outside sensor BS	AF		Boiler Controller	13.1a
5005	PE1 Outside sensor SC	AF		Boiler Controller	13.1b
5006	PE1 Boiler sensor BS	KF		Boiler Controller	13.1a
5007	PE1 Boiler sensor SC	KF		Boiler Controller	13.1b
5008	PE1 Fluegas sensor BS	RGF		Boiler Controller	13.4
5009	PE1 Fluegas sensor SC	RGF			
5010	PE1 Combustion sensor BS	FRT			
5011	PE1 Combustion sensorSC	FRT			
5012	PE1 Underpressure box BS	UP		Boiler Controller	13.5
5013	PE1 Underpressure box SC	UP			
5014	PE1 Analog input1 BS	AE1		Boiler Controller	13.6
5015	PE1 Analog input1 SC	AE1			
5016	PE1 Analog input2 BS	AE2			
5017	PE1 Analog input2 SC	AE2			
5018	PE1 Motor turbine	VAK		Boiler Controller	13.7
5019	PE1 Ignition	ZUEND		Boiler Controller	13.8
5020	PE1 Motor ashbox	AV		Boiler Controller	13.9
5021	PE1 Motor res 1	RES1		Boiler Controller	13.10
5022	PE1 Magnetic valve	MA		Boiler Controller	13.8
5023	PE1 Motor cleaning	RM			

Code	Display	Input / Output		Affected element	Solution table
5024	PE1 Flue gas fan	SZ		Boiler Controller	13.9
5025	PE1 Cirkulationspump	UW			
5026	PE1 Motor ext auger1	RA		Boiler Controller	13.11
5027	PE1 Motor ext auger2	ZW		Boiler Controller	13.9
5028	PE1 Motor between	RES1		Boiler Controller	13.12
5029	PE1 Motor boiler auger	ES		Boiler Controller	13.9
5030	PE1 Combustion Fan	LUFT			
5032	PE1 Emergency stop	NOT		Boiler Controller	13.13
5033	PE1 Max temp sensor	STB			
5034	PE1 Ignition fault	generic		Boiler Controller	13.14
5036	PE1 Low flame temp				
5038	PE1 Firedamper open	BSK 1 2		Boiler Controller	13.15
5039	PE1 Firedamper closed	BSK 3 4			
5040	PE1 Firedamper end switch	BSK 1 2 3 4			
5041	PE1 Low underpressure	UP, SZ, LUFT		Boiler Controller	13.5
5042	PE1 Low underpressure	UP, SZ, LUFT			
5043	PE1 Vacuum system	KAPZW, RA		Boiler Controller	13.16
5044	PE1 Ashbox full	ESAV, AV		Boiler Controller	13.17
5045	PE1 Ball lock	DE1		Boiler Controller	13.18
5047	PE1 Burner Motor	ES		Boiler Controller	13.19
5048	PE1 Burner gas open-circuit	RGF		Boiler Controller	13.4
5049	PE1 Burner gas short-circuit				
5052	PE1 Container cover open	AK		Boiler Controller	13.20
5053	PE1 ash warning	ESAV, AV		Boiler Controller	13.17
5054	PE1 pellets warning	AE1		Boiler Controller	13.21

13.1a Sensors KTY2K - Heating controller + Boiler Controller (Fault 1001 to 1020 and 5000 to 5007) – Sensor break

Type of fault	Sensor break		
Code:	1001	HC1 Flow BC	X4
	1002	DHW1 OnSensor BC	X6
	1003	Outside Sensor BC	X2
	1004	Boiler Sensor BC	X3
	1008	TPO1 BC	X7
	1009	TPM1 BC	X8
	1011	TPU1 BC	X9

	1012	Flow Energy1 BS	X16
	1013	Return Energy1 BS	X17
	1014	ExistBoiler1 BS	X13
	1017	Cascade OnSensor BC	X3
	1018	Cascade OffSensor BC	X3
	1019	Circulation Return1 BC	X14
	1020	DHW1 Off Sensor BC	X6
	5000	PE1 Reserve sensor1 BS	R1
	5002	PE1 Reserve sensor2 BS	R2
	5004	PE1 Outside sensor BS	AF
	5006	PE1 Boiler sensor BS	KF
Description:	Measuring circuit of KTY sensor is open		
Cause and Remedy:	sensor not connected	▶	connect sensor, check plug
	sensor defect	▶	measure sensor (approx. $2k\Omega$ at 25°C) replace if required
	sensor cable defect	▶	replace sensor
	sensor temperature too high	▶	sensor temperature above measuring range ($>110^{\circ}\text{C}$)

13.1b Sensors KTY2K - Heating controller + Boiler Controller (Fault 2001 to 2020 and 5000 bis 5007) - short circuit

Type of fault	Short circuit		
Code :	2001	HC1 Flow SC	X4
	2002	DHW1 OnSensor SC	X6
	2003	Outside Sensor SC	X2
	2004	Boiler Sensor SC	X3
	2008	TPO1 SC	X7
	2009	TPM1 SC	X8
	2011	TPU1 SC	X9
	2012	Flow Energy1 SC	X16
	2013	Return Energy 1 SC	X17
	2014	ExistBoiler1 SC	X13
	2017	Cascade OnSensor SC	X3
	2018	Sonde arrêt cascade CC	X3
	2019	Circulation Return1 SC	X14
	2020	WW1 Aus Fühler KS	X6
	5001	PE1 Reserve sensor1 SC	R1
	5003	PE1 Reserve sensor2 SC	R2
	5005	PE1 Outside sensor SC	AF
	5007	PE1 Boiler sensor SC	KF
Description:	Measuring circuit of KTY sensor is shorted out		
Cause and Remedy:	Sensor defect	▶	Measure sensor (approx. 2k Ω at 25°C), replace if required
	Sensor cable defect	▶	Replace sensor
	Sensor temperature too low	▶	Sensor temperature below measuring range (<-10°C)

13.1c Sensors KTY2K - Heating controller + Boiler Controller (Fault 3001 to 3020) - other faults

Type of fault	Other faults		
Code:	3001	HC1 Flow	X4
	3002	DHW1 OnSensor	X6
	3003	Outside Sensor	X2
	3004	Boiler Sensor	X3
	3008	TPO1	X7
	3009	TPM1	X8
	3011	TPU1	X9
	3012	Flow Energy1	X16
	3013	Return Energy1	X17
	3014	ExistBoiler1	X13
	3017	Cascade OnSensor	X3
	3018	Cascade OffSensor	X3
	3019	Circulation Return1	X14
	3020	DHW1 Off Sensor	X6
Cause and Remedy:	Sensor defect	▶	Measure sensor (approx. 2k Ω at 25°C), replace if required
	Sensor cable defect	▶	Replace sensor
	Sensor input defect	▶	Replace Boiler controller

13.2 Kollektor sensor (Fault 1010, 2010, 3010)

Display:	[1010] Kollektor BC		
Description:	Collector sensor fracture, measuring circuit of collector sensor (X15) is open		
Cause and Remedy:	Sensor not connected	▶	Check and correct wiring
	Sensor defect	▶	Measure sensor (approx. 1,1k Ω at 25°C), replace if required
	Sensor cable defect	▶	Replace sensor
Display:	[2010] Kollektor SC		
Description:	Measuring circuit of collector sensor (X15) is shorted out		
Cause and Remedy:	Sensor defect	▶	Measure sensor (approx. 1,1k Ω at 25°C), replace if required
	Sensor cable defect	▶	Replace sensor
Display:	[3010] Kollektor		
Description:	Other fault at input X15		
Cause and Remedy:	Sensor defect	▶	Replace sensor
	Sensor cable defect	▶	Replace sensor
	Input on heating controller defect	▶	Replace input on heating controller

13.3 Bus (Fault 4005, 4006, 4007, 4015, 4016)

Display:	[4005] BUS HCR		
Description:	Time-Out of BUS-connection from touch operating device to heating controller		
Cause and Remedy:	Wrong cable connection	▶	Check cable connection
	No power supply available	▶	Connect heating controller to BUS
	Fuse in heating controller defect	▶	Replace fuse
Display:	[4006] BUS PE		
Description:	Time-Out of BUS-connection from touch operating device to boiler controller		
Cause and Remedy:	Wrong cable connection	▶	Check cable connection
	No power supply available	▶	Connect heating controller to power supply (X21)
	Fuse in heating F2 defect	▶	Replace fuse F2
Display:	[4007] BUS Remote		
Description:	Time-Out of BUS-connection of remote control		
Cause and Remedy:	Wrong cable connection	▶	Check cable connection
	Remote controll defect	▶	Replace remote controll
Display:	[4015] BUS Remote Touch		
Description:	Time-Out of BUS-Connection from remote controll to Touch operating device		
Cause and Remedy:	Wrong cable connection	▶	Check cable connection
	Wrong softwareversion	▶	Check version of software
Display:	[4016] BUS Master		
Description:	Missing BUS connection to master-operating device		
Cause and Remedy:	Wrong cable connection	▶	Check cable connection

13.4 Combustion chamber sensor (Fault 5010, 5011, 5048, 5049)

Display:	[5010] PE Combustion sensor BS		
Description:	Combustion chamber sensor fracture, measuring circuit from combustion chamber sensor is open - Input FRT		
Cause and Remedy:	Sensor not connected	▶	Connect sensor at input
	Sensor defect	▶	Measure sensor (approx. 5 mV at 125°C) replace if required
	Sensor cable defect	▶	Replace sensor
	Sensor temperature too high	▶	Sensor temperature above measuring range (1100°C)
Display:	[5011] PE Combustion sensor SC		
Description:	Combustion chamber sensor short circuit, measuring circuit from combustion chamber sensor short circuit - Input FRT		

Cause and Remedy:	Sensor defect	▶	Measure sensor (approx. 5 mV at 125°C) replace if required
	Sensor cable defect	▶	Replace sensor
	Sensor temperature too low	▶	Sensor temperature below measuring range (- 10°C)
	Sensor polarity reversed	▶	Change sensor connection + and -
Display:	[5048] PE Burner gas open-circuit (only SMART without combustion chamber sensor)		
Description:	Burner gas sensor fracture, measuring circuit of Burner gas sensor is open - Output RGF		
Cause and Remedy:	Sensor not connected	▶	Connect sensor at input
	Sensor cable defect	▶	Replace sensor
	Sensor defect	▶	Measure sensor (NiCrNi) replace if required
	Sensor temperature too high	▶	Sensor temperature above measuring range (1100°C)
Display:	[5049] PE Burner gas short-circuit (only SMART without combustion chamber sensor)		
Description:	Burner gas sensor short circuit, measuring circuit of Burner gas sensor short circuit - Output RGF		
Cause and Remedy:	Sensor defect	▶	Measure sensor (approx.. 5mV at 125°C) replace if required
	Sensor cable defect	▶	Replace sensor
	Sensor temperature too low	▶	Sensor temperature below measuring range (- 10°C)
	Sensor polarity reversed	▶	Change sensor connection + and -

13.5 Underpressure box (Fault 5012, 5013, 5041, 5042)

Display:	[5012] PE Underpressure box BS		
Description:	Negative draft input open, measuring circuit from negative draft measurement open - Input UP		
Cause and Remedy:	Signal incorrect	▶	Check poarity and signal (0-10V)
	Signal cable defect	▶	Replace sensor
	No signal	▶	Replace underpressure box
	Combustion chamber leak	▶	Check total closure of boiler door

Display:	[5013] PE Underpressure box SC		
Description:	Negative draft input short-circuit, measuring circuit from negative draft measurement is shorted out - Input UP		
Cause and Remedy:	Signal incorrect	▶	Check poarity and signal (0-10V)
	Signal cable defect	▶	Replace sensor
	Signal too high	▶	Signal above 10V
Display:	[5041] [5042] PE Low underpressure		
Description:	Negative draft pressure in boiler is not achieved [5041] or is too high [5042] - Exit LUFT (SMART + Condens) / Output SZ (PE+PEK)		
Cause and Remedy:	Negative draft tube disconnected	▶	Connect up negative draft tube
	Negative draft does not change	▶	Check negative draft tube for leaks. Check flue gas tube for blockage.
	Negative draft pressure too low	▶	Close boiler door, check tube to negative draft sensor, check whether boiler flue gas outlet is clear, check whether condensation heat exchanger is clear. Make sure flue gas fan is running.
	Negative draft pressure too high	▶	Check induced draft blower

13.6 Analog input (Fault 5014, 5015, 5016, 5017)

Display:	[5014] / [5016] PE Analog input 1/2 BS		
Description:	Analog input 1/ 2 sensor fracture, measuring circuit of Analog input sensor open - Output AE1 / AE2		
Cause and Remedy:	Signal incorrect	▶	Check poarity and signal (0-10V)
	Signal cable defect	▶	Replace sensor
	Level detection system activated (valid for AE2)	▶	Check settings
Display:	[5015] / [5017] PE Analog input 1/2 SC		
Description:	Analog input 1/ 2 sensor short circuit, measuring circuit of Analog input sensor is shorted out - Input AE1/AE2		
Cause and Remedy:	Signal incorrect	▶	Check poarity and signal (0-10V)
	Signal cable defect	▶	Replace sensor
	Signal too high	▶	Signal above 10V

13.7 Motor turbine (Fault 5018)

Display:	[5018] PE Motor Turbine		
Description:	Vaccuum turbine not running (Exit VAK)		
Cause and Remedy:	Motor unplugged	▶	Plug in motor, check cable connections
	Motor defect	▶	Replace motor
	Fuse F1, suction circuit board defective	▶	Replace fuse

13.8 Output 230V (Fault 5019, 5022, 5023)

Display:	[5019] PE Ignition [5022] PE Magnetic valve [5023] PE Motor cleaning		
Description:	No function of output ZUEND (Ignition)/MA (Magnetic valve)/ RM (Motor cleaning)		
Cause and Remedy:	Output unplugged	▶	Connect plug, check cable wiring
	Current value above the maximal Limit	▶	Check limits
	Current value under the minimal Limit	▶	Check limits

13.9 Output 230V-2 (Fault 5020, 5024, 5025, 5027, 5029, 5030)

Display:	[5020] PE Motor ashbox (Output AV) [5024] PE Flue gas fan (Output SZ) [5025] PE Cirkulationspump (Output UW) [5027] PE Motor ext auger2 (Output RES2) [5029] PE Motor boiler auger (Output ES) [5030] PE Combustion Fan (Output LUFT)		
Description:	No function of the respective motor/pump/fan		
Cause and Remedy:	Motor/pump/fan unplugged	▶	Connect plug, check cable wiring
	Motor/pump/fan defect	▶	Replace motor/pump/fan

13.10 Zwischenbehälter leer - Motor res 1 (Fault 5021)

Display:	[5021] PE Hopper empty / Motor RES1 (for 36-56 kW, Pellematic Condens or PEB)		
Description:	No function of PE motor res 1		
Cause and Remedy:	Motor unplugged	▶	Plug in motor, check cable connections
	Motor defect	▶	Replace motor
	No pellets available	▶	Refill storage-Room / supply tank

13.11 Motor extraction auger 1 - RA (Fault 5026)

Display:	[5026] Motor ext auger1		
Description:	Storage room auger 1 motor defect - Output RA		
Cause and Remedy:	Motor unplugged	▶	Plug in motor, check cable connections
	motor is jammed	▶	Remove pellets and dust from auger and make sure auger rotates freely
	Motor defect	▶	Replace motor
	Thermic contact triggered	▶	Let motor cool down
	Motor not running	▶	Check thermic contact

13.12 Hopper motor (Fault 5028)

Display:	[5028] Hopper motor		
Description:	Hopper suction fan fault. Output ZW.		
Cause and Remedy:	Motor unplugged	▶	Plug in motor, check cable connections
	Motor defect	▶	Replace motor

13.13 Emergency OFF/ Safety temperature (Fault 5032, 5033)

Display:	[5032] Emergency OFF - NOT AUS		
Description:	Emergency OFF has been actuated - Input NOT-AUS		
Cause and Remedy:	Emergency OFF unplugged	▶	Connect up Emergency OFF and check cable connections
	Emergency OFF button has been pressed	▶	Reset Emergency OFF switch
	Emergency OFF defect	▶	Replace Emergency OFF switch
Display:	[5033] Safety temperature - STB		
Description:	Safety temperature limiter has tripped - Input STB		
Cause and Remedy:	Safety temperature limiter unplugged	▶	Connect up safety temperature limiter and check cable connections
	Safety temperature limiter has tripped	▶	Let boiler cool down and reset safety temperature limiter
	Safety temperature limiter defect	▶	Replace safety temperature limiter
	A 230V Output is defect	▶	Check 230V Outputs

13.14 Temperature Combustion chamber sensor/Flue gas sensor (Fault 5034, 5036)

Display:	[5034] PE Ignition fault / Pellets available?		
Description:	Minimum temperature Combustion chamber sensor/Flue gas sensor not reached during the ignition phase		
Cause and Remedy:	No pellets available	▶	Fill up with pellets
	Ignition electrode defect	▶	Check ignition electrode (approx. 200Ω) replace if required
	Ignition nozzle blocked	▶	Clean burner plate and ignition tube

	Not enough draught	▶	Check ventilation flap, funktion radial fan, draught free
	Flue gas sensor or flamm-roomtemperature-sensor soiled	▶	Check Flue gas sensor or flammroom-temperature-sensor
Display:	[5036] PE Flame supervision fault		
Description:	Flame supervision fault, minimum flue gas temperature not reached during heating up at full power - Input FRT		
Cause and Remedy:	No pellets available	▶	Fill up with pellets

13.15 Flame return gate BSK (5038, 5039, 5040)

Display:	[5038] PE Flame return gate open		
Description:	Flame return gate open fault (BSK - 12)		
Cause and Remedy:	Flame return gate unplugged	▶	Connect up flame return gate and check cable connections
	Flame return gate does not reach OPEN limit switch	▶	Check ball valve to see if it is jammed
	No signal although open	▶	Check cables and flame return gate
Display:	[5039] PE Flame return gate closed		
Description:	Flame return gate open fault		
Cause and Remedy:	Flame return gate unplugged	▶	Connect up flame return gate and check cable connections
	Flame return gate does not reach CLOSE limit switch	▶	Check whether ball valve is jammed, check ball valve throughway to see if foreign objects are preventing it from closing
	No signal although closed	▶	Check cables and flame return gate
Display:	[5040] PE Flame return gate limit switch		
Description:	Both flame return gate limit switches (BSK 1-2 and BSK 3-4) are closed at the same time		
Cause and Remedy:	Both limit switches activated	▶	Check flame return gate, check cables, check connectors

13.16 Suction system (Fault 5043)

Display:	Suction system		
Description:	Hopper cannot be filled up even after 3 suction cycles		
Cause and Remedy:	Storage room empty	▶	Fill up with pellets
	Extraction system is blocked	▶	Clear extraction system
	Extraction system not conveying pellets	▶	Pellet bridge - destroy bridge and make sure material flows properly

	Suction fan unplugged	▶	Connect up suction fan
	Storage room auger motor unplugged	▶	Connect up storage room motor

13.17 Ashbox full (Fault 5044) - Ash Warning (Fault 5053)

Display:	[5044] PE Ashbox full		
Description:	Moter doesn't reach the normal speed after 3 attempts.		
Display:	[5053] PE Ash Warning		
Description:	Ash-box nearly full		
Cause and Remedy:	Ash-box full	▶	Clear ash-box
	Ash-box not completely closed	▶	Close ash-box
	End-switch defect	▶	Replace end-switch

13.18 Ball lock (Smart and Condens only - Fault 5045)

Display:	[5045] PE Ball lock - Smart and Condens only		
Description:	No pellets detected from capacitive sensor (KAP RA)		
Cause and Remedy:	Pellet reserves depleted	▶	Refill storage-Room / supply tank
	Capacitive sensor RA defect	▶	Replace Capacitive sensor RA

13.19 Burner Motor / Ash box full (SMART and Condens only - Fault 5047)

Display:	[5047] Burner Motor /Ash box full - SMART only		
Description:	The alarm text is displayed after the motor has made 3 unsuccessful attempts to reach the normal speed of the external de-ashing system.		
Cause and Remedy:	Ash box is full	▶	Empty ash box
	Rotation of burner auger or ash auger is blocked	▶	Ensure rotation of auger

13.20 Container cover open (PEB only - Fault 5052)

Display:	[5052] PE Container cover open		
Description:	Container cover open (PEB only) - Input AK		
Cause and Remedy:	Cover open	▶	Close cover
	End-switch defect	▶	Replace end-switch

13.21 Pellets Warning (Fault 5054)

Display:	[5054] PE 1 Pellets Warning		
Description:	Measured pellets capacity (AE2) is below the threshold		
Cause and Remedy:	Pellets nearly empty or empty	▶	Fill up with pellets
	Sensor unpugged (AE2)	▶	Connect plug
	Parameter set incorrectly	▶	Check settings in menu Level detection system (protected access)



Author

ÖkoFEN Forschungs- &
EntwicklungsgesmbH
A-4133 Niederkappel, Gewerbepark 1
Tel.: +43 (0) 72 86 / 74 50
Fax.: +43 (0) 72 86 / 74 50 - 10
E-Mail: oekofen@pelletsheizung.at
www.oekofen.com

© by ÖkoFEN Forschungs- und EntwicklungsgesmbH
Subject to modifications